

To : \_\_\_\_\_

**Tentative**

## Specification of FDTC TFT-LCD module

**FLC48SXC8V-12F**

Approval

Date :

By :

This Product is designed, developed and manufactured as contemplated for general use, including without limitation, general office use, personal use, household use, and ordinary industrial use, but is not designed, developed and manufactured as contemplated for use accompanying fatal risks or dangers that, unless extremely high safety is secured, could lead directly to death, personal injury, severe physical damage or other loss (hereinafter "High Safety Required Use"), including without limitation, nuclear reaction control in nuclear facility, aircraft flight control, air traffic control, mass transport control, medical life support system, missile launch control in weapon system. Fujitsu shall not be liable against the Customer and/or any third party for any claims or damages arising in connection with the High Safety Required Use of the Product without permission.

Specification No. : Tech Bes LCD-00287

Issue Date : Sep., 10, 2004

Issued by :

*F. Yamada*

F. Yamada  
Director

Products Engineering Dept., LCD Products Div.

**FUJITSU DISPLAY TECHNOLOGIES CORPORATION**

Tentative

REVISION HISTORY

A

A

Revision	Date	Prepared	Checked		Approved	Summary
01A	Aug. 30,2004	K.Nukiyama	K.Yonemura	T.Ito	F.Yamada	1 <sup>st</sup> issue

B

B

C

C

D

D

E

DATE	
DOCUMENT CONTROL SECTION	

						TITLE	FLC48SXC8V-12F	
						DRAW. NO.	Tech Bes LCD-00287	CUST.
02	20040910	Nukiyama	Yonemura	T.Ito	Modified P6,P8	FUJITSU DISPLAY TECHNOLOGIES CORPORATION		
EDIT	DATE	DESIG.	CHECK	APPR.	DESCRIPTION	CORPORATION		1 / 38
DESIG.	20040830	K.Nukiyama	CHECK	K.Yonemura	APPR.	T.Ito		

F

**Tentative**

**TABLE OF CONTENTS**

1.	APPLICATIONS	3
2.	PRODUCT NAME AND MODEL NUMBER	3
2-1.	Product Name	3
2-2.	Model Number	3
3.	OVERVIEW	3
4.	CONFIGURATION	3
5.	MECHANICAL SPECIFICATIONS	4
6.	ABSOLUTE MAXIMUM RATING	5
7.	RECOMMENDED OPERATING CONDITIONS	5
8.	ELECTRICAL SPECIFICATIONS	6
9.	OPTICAL SPECIFICATIONS	8
10.	INTERFACE SPECIFICATIONS	12
10-1.	Signal Descriptions	12
10-2.	LVDS Data Assignment	13
10-3.	Color Data Assignment	15
10-4.	Input Signal Timing	16
10-5.	Correspondence between Data and Display Position	18
10-6.	Power Supply Sequence	18
11.	BACK-LIGHT SPECIFICATIONS	19
11-1.	Pin configuration for Back-light	19
11-2.	Life	19
11-3.	Lamp assembly set	19
12.	APPEARANCE SPECIFICATIONS	20
12-1.	Appearance	20
12-2.	Dot defects	21
13.	ENVIRONMENTAL SPECIFICATIONS	22
14.	INDICATIONS	23
15.	PACKAGING	23
15-1.	Packing Specifications	23
15-2.	Packing Method	23
16.	WARRANTY	29
17.	PRECAUTIONS	29
18.	PRECAUTIONS FOR USE	36
19.	MISCELLANEOUS	36

A

A

B

B

C

C

D

D

DATE DOCUMENT CONTROL SECTION

E

F

						TITLE <b>FLC48SXC8V-12F</b>	
						DRAW. NO. <b>Tech Bes LCD-00287</b>	
						CUST.	
EDIT	DATE	DESIG.	CHECK	APPR.	DESCRIPTION	FUJITSU DISPLAY TECHNOLOGIES CORPORATION	
						2/	

**Tentative**

**1. APPLICATION**

This specification is applied to the 19-inch SXGA supported TFT-LCD module.

A

A

**2. PRODUCT NAME AND MODEL NUMBER**

2-1 Product Name : **LCD Module**

2-2 Model Name : FLC48SXC8V-12F

2-3 Drawing Number : NA19026-C292

B

B

**3. OVERVIEW**

This LCD module has a TFT active matrix type liquid crystal panel 1280x1024 pixels, and diagonal size of 48cm(19-inch). This LCD has a LVDS dual interface and can display 16,777,216 colors.

This module includes Fast Response time Driving circuit.

The power supply of this LCD module is +5V DC voltage.

C

C

**4. CONFIGURATION**

This LCD module consists of a color TFT-LCD panel that is mounted with TFT driver ICs and a cold-cathode fluorescent tube back-light.

The inverter for the back-light is not included.

Figure 4-1 shows a block diagram of this LCD module.

D

D

DOCUMENT CONTROL SECTION

DATE

E

F

						TITLE		FLC48SXC8V-12F	
						DRAW. NO.			CUST.
						Tech Bes LCD-00287			
EDIT	DATE	DESIG.	CHECK	APPR.	DESCRIPTION				FUJITSU DISPLAY TECHNOLOGIES CORPORATION
DESIG.			CHECK			APPR.		3 /	

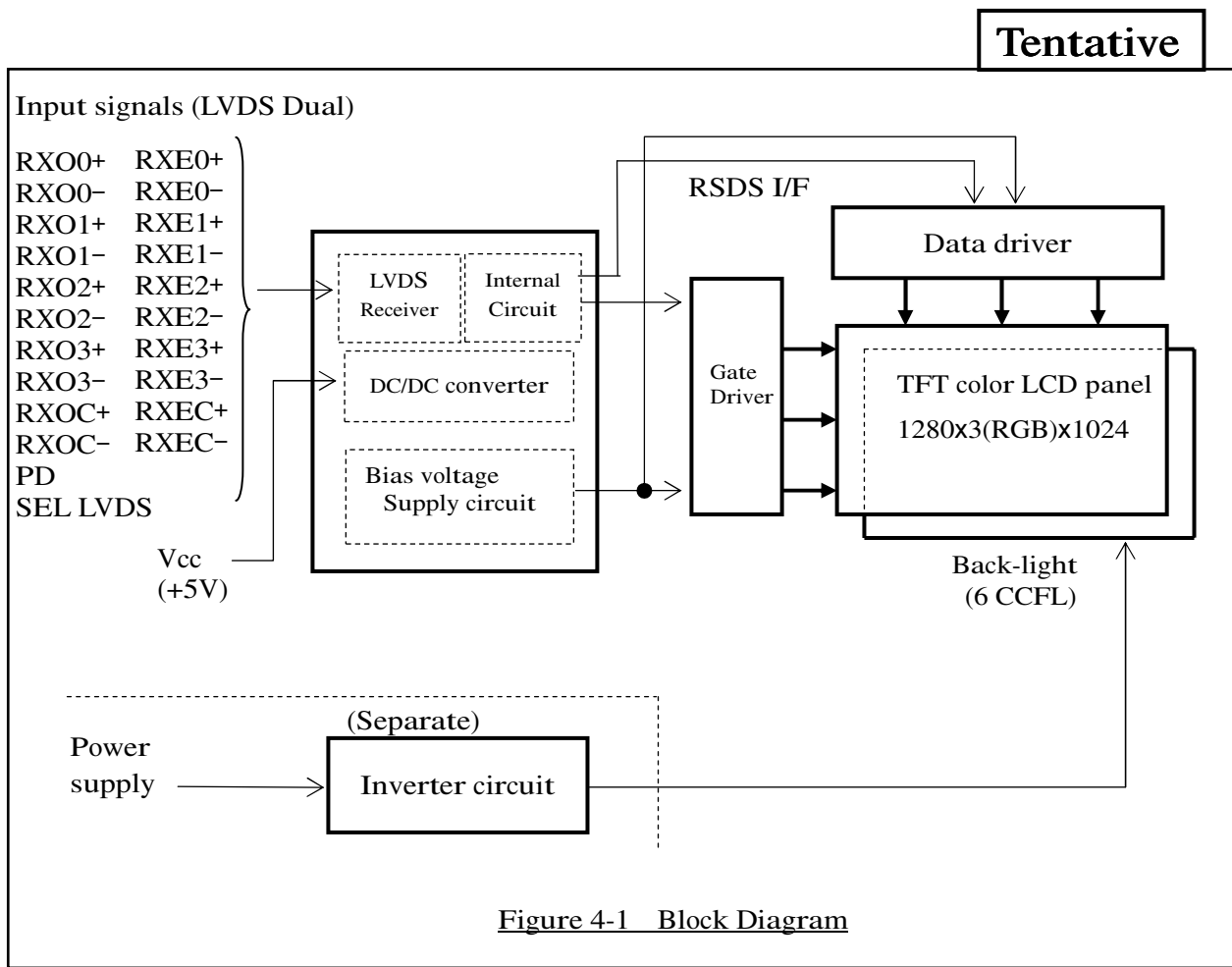

## 5. MECHANICAL SPECIFICATIONS

Table 5-1 shows the mechanical specifications of this LCD module.

**Table 5-1 Mechanical Specifications**

Item	Specifications	Unit	Remark
Dimensions	404.2x3330x22(TYP.)	mm	Edge type back-light is used. (CCFLx6)  Without inverter.  For details on dimensions, see dimensional outline drawing. (Figure 20-1,2)  Excluding inverter.
Display Resolution	(1280x3)x1024	—	
Display Dot Area	376.32x301.056	mm	
Dot Pitch	(0.098x3)x0.294	mm	
Pixel Aspect Ratio	1:1	—	
Weight	3,200 MAX.	g	
FG-SG	Short circuit	—	

DOCUMENT CONTROL SECTION

DATE

						TITLE		FLC48SXC8V-12F	
						DRAW. NO.		Tech Bes LCD-00287	
						CUST.			
EDIT	DATE	DESIG.	CHECK	APPR.	DESCRIPTION				
DESIG.			CHECK		FUJITSU DISPLAY TECHNOLOGIES CORPORATION				
						4 /			

**Tentative**

### 6. ABSOLUTE MAXIMUM RATING

Table 6-1 shows the absolute maximum rating of this LCD module.

Table 6-1 Absolute Maximum Rating

Item	Symbol	Condition	MIN.	TYP.	MAX.	Unit
Supply Voltage	V <sub>CC</sub>	Ta=25°C	-0.3	—	6.0	V
Input Signal Voltage (LVDS signal, PD,SEL LVDS )	V <sub>IN</sub>	Ta=25°C	-0.3	—	3.6	V

### 7. RECOMMENDED OPERATING CONDITIONS

Table 7-1 shows the recommended operating conditions of this LCD module.

Table 7-1 Recommended Operating Conditions

Item	Symbol	MIN.	TYP.	MAX.	Unit
Supply Voltage(Logic)	V <sub>CC</sub>	4.75	—	5.25	V
Ripple Voltage	V <sub>CC</sub>	V <sub>RP</sub>	—	0.1	V

DATE DOCUMENT CONTROL SECTION

						TITLE <b>FLC48SXC8V-12F</b>	
						DRAW. NO. <b>Tech Bes LCD-00287</b>	
						CUST.	
EDIT	DATE	DESIG.	CHECK	APPR.	DESCRIPTION	FUJITSU DISPLAY TECHNOLOGIES CORPORATION	
DESIG.			CHECK		APPR.	5/	

Tentative

### 8. ELECTRICAL SPECIFICATIONS

Table 8-1 shows the electrical specifications of this LCD module. Figure 8-1 shows the measurement circuit. Figure 8-2(A) shows the equivalent circuit of the logic signal input area. Figure 8-2(B) shows the equivalent circuit of the supply voltage Input area.

**Table 8-1 Electrical Specifications**

Item	Symbol	Condition	MIN.	TYP.	MAX.	Unit	Remark
Differential-input Voltage (Hign)	V <sub>IH</sub>	V <sub>CM</sub> =+1.2V	—	—	100	mV	
Differential-input Voltage (Low)	V <sub>IL</sub>		-100	—	—	mV	
Input Voltage (High)	V <sub>IH</sub>	V <sub>CC</sub> =+5.0±0.25V V <sub>SS</sub> =0V DCLK=54MHz Ta=25° C	2.0	—	3.3	V	PD SEL LVDS
Input Voltage (Low)	V <sub>IL</sub>		0	—	0.8	V	
Supply Current	I <sub>CC</sub>		—	(1350)	(2500)	mA	*1
Supply Rush Current	I <sub>SCC</sub>		—	—	3.5	A	*2
Supply Rush Current Duration(1.5A excess)	T <sub>SCC</sub>	—	—	1.0	ms		
B A C K	CCFL Turn on Voltage	V <sub>s</sub>	f <sub>L</sub> =50kHz, Ta=25°C	—	1400	1600	V <sub>rms</sub>
			f <sub>L</sub> =50kHz, Ta=0°C	—	1500	1600	
L I G H T	Lighting Voltage	V <sub>L</sub>	f <sub>L</sub> =50kHz I <sub>L</sub> =7mA	—	750	—	V <sub>rms</sub>
	Lighting Frequency	f <sub>L</sub>	V <sub>L</sub> =750V <sub>rms</sub>	40	50	60	kHz
	(*3) Tube Current	I <sub>L</sub>	f <sub>L</sub> =50kHz V <sub>L</sub> =750V <sub>rms</sub>	4	7	8	mArms *4

(\*1) Typical current situation : Color bar pattern. V<sub>CC</sub>=5.0V  
 Maximum current situation : White pattern. V<sub>CC</sub>=4.75V  
 Without rush current.

(\*2) These items prescribe the rush current for starting internal DC/DC.  
 Charging current to capacitors of V<sub>CC</sub> is not prescribed.

(\*3) Back-light specifications are valid when using a suitable inverter such as the FLCV-16

② (\*4) Tube current (I<sub>L</sub>) shows the value of the current that is consumed at one lamp.  
 This LCD module has 46 lamps. Each 23 lamps are placed at upper side and lower side of the display.  
 23 lamps is connected in parallel. Each low voltage terminals are connected with separate cable to Back-light connector.

DOCUMENT CONTROL SECTION

DATE

						TITLE		FLC48SXC8V-12F	
						DRAW. NO.		Tech Bes LCD-00287	
						CUST.			
02		20040910				Modified Note4			
EDIT	DATE	DESIG.	CHECK	APPR.	DESCRIPTION				
DESIG.			CHECK		APPR.	FUJITSU DISPLAY TECHNOLOGIES CORPORATION			

6/

**Tentative**

Measurement circuit is based on Figure 8-1.

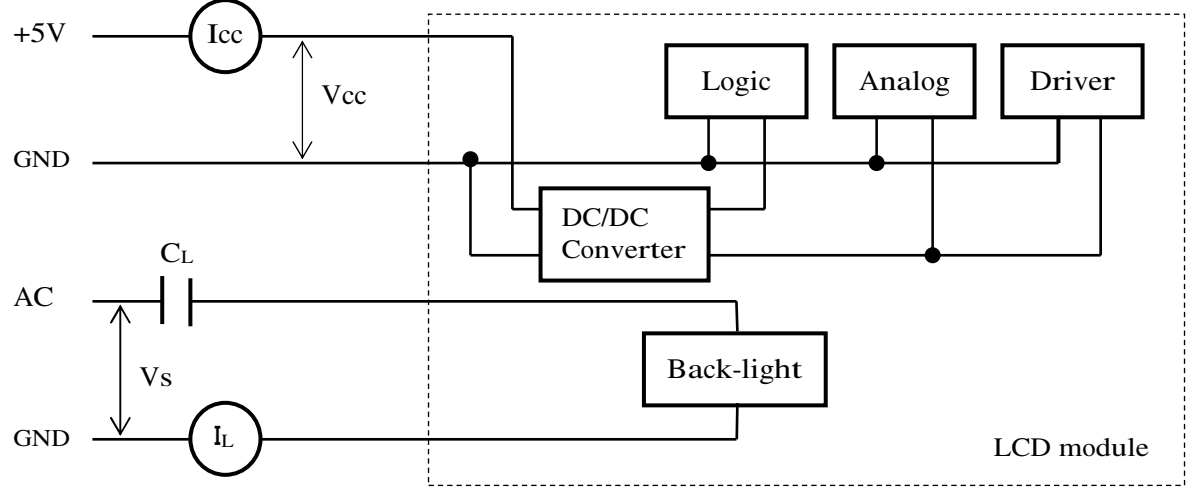

**Figure 8-1 Measurement circuit**

Input signals (LVDS Dual)

- RX00+ RXE0+
- RX00- RXE0-
- RX01+ RXE1+
- RX01- RXE1-
- RX02+ RXE2+
- RX02- RXE2-
- RX03+ RXE3+
- RX03- RXE3-
- RXOC+ RXEC+
- RXOC- RXEC-

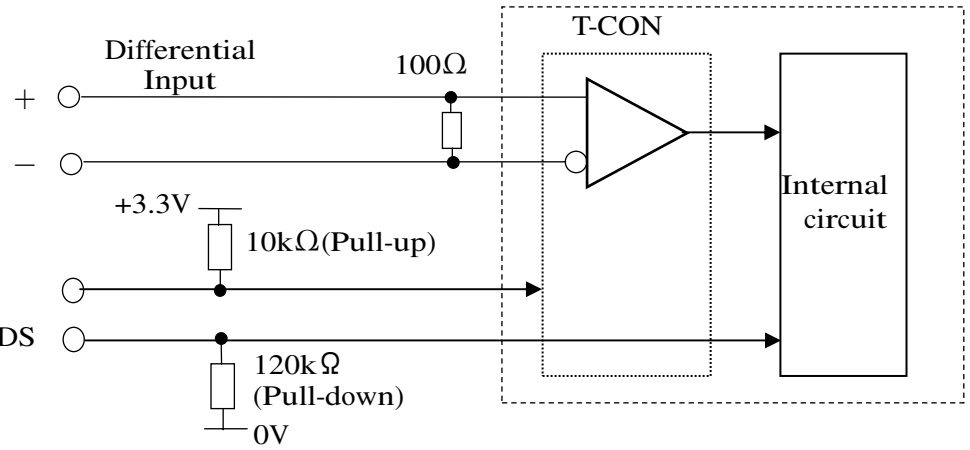

**Figure 8-2(A) Equivalent circuit of logic signal Input**

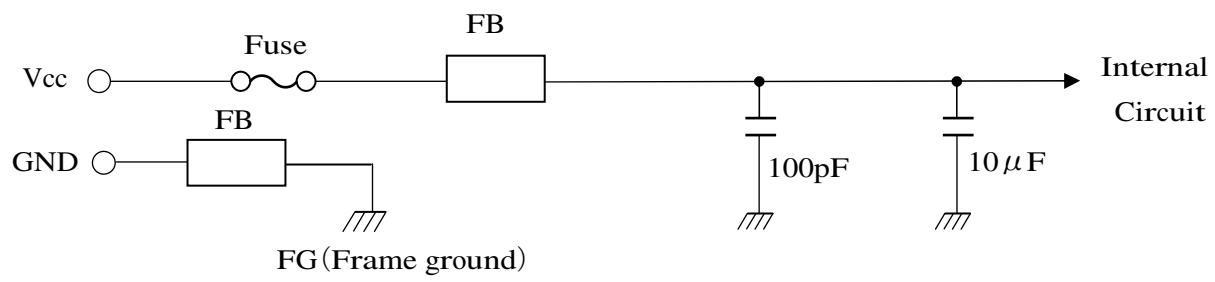

**Figure 8-2(B) Equivalent circuit of power supply**

DOCUMENT CONTROL SECTION

DATE

EDIT	DATE	DESIG.	CHECK	APPR.	DESCRIPTION				
DESIG.			CHECK				APPR.		

TITLE		FLC48SXC8V-12F	
DRAW. NO.		Tech Bes LCD-00287	
CUST.			
FUJITSU DISPLAY TECHNOLOGIES CORPORATION		7/	



Tentative

## 9. OPTICAL SPECIFICATIONS

Table 9-1 shows the optical specifications of this LCD module.

Table 9-1 Optical Specifications

Ta=25°C, Signal timing=Typ.

Item	Symbol	Condition	Specifications			Unit	Remark		
			MIN.	TYP.	MAX.				
Visual Angle	Horizontal	$\theta_{L,R}$	CR $\geq$ 10	$\theta_{U,D}=0^\circ$	85	89	—	deg	(1)(2) (3)(5) (6)
	Vertical	$\theta_{U,D}$		$\theta_{L,R}=0^\circ$	85	89	—	deg	
	All Direction	$\theta$		—	80	—	deg		
Contrast Ratio	CR	$\theta_{L,R,U,D}=0^\circ$		400	600	—	—	White/Black	(1)(2) (3)(5)
Response Time(Rise+Fall) (B→W→B)	$\tau_{rise} + \tau_{fall}$	$\theta_{L,R,U,D}=0^\circ$	Ta=25°C	—	12	—	ms	(1) (4) (5)	
			Ta=0°C	—	24	—	ms		
Response Time (Rise or Fall) (All gray scale)	$\tau_{avg}$	$\theta_{L,R,U,D}=0^\circ$	Ta=25°C	—	8	—	ms	Average of Response Time,	
Brightness	I	$\theta_{L,R,U,D}=0^\circ$		320	450	—	cd/m <sup>2</sup>	White *1	(1)(5)
Brightness Uniformity	$\Delta I$	V <sub>CC</sub> =5V I <sub>L</sub> =7mA		70	—	—	%		(1)(5) (7)
Chromaticity	W	x	fL=50kHz R*,G*,B* Signal =All "H"	0.283	0.313	0.343	—		(1) (5)
		y		0.299	0.329	0.359	—		
	R G B	(x, y)	Red	(0.640, 0.349) Typ.					
			Green	(0.283, 0.598) Typ.					
			Blue	(0.142, 0.071) Typ.					
LCD Panel Type				TFT Color					
Display Mode				Normaly Black					
Wide Viewing Angle Technology				MVA-Premium					
Optimum Viewing Angle				— (symmentry)				(6)	
Display Color				16,777,216 (8-bit color)					
Color of non-display area				Black					
Surface Treatment				Anti Glare (Haze value:(25%), 2H)					

(\*1) Value at 15~20 minutes after lighting on.

(Note) •CS-1000 (MINOLTA Co., Ltd.) Field=1°, L=500mm

• Back-light current = 7mA, Dark room condition(1 lux or less)

Be carefull that the luminance meter, which you use, may not be able to get correct brightenss if it's no set correctly.

DOCUMENT CONTROL SECTION

DATE

						TITLE		FLC48SXC8V-12F	
						DRAW. NO.		Tech Bes LCD-00287	
						CUST.			
02	20040910	Nukiyama			Modified Surface treatment				
EDIT	DATE	DESIG.	CHECK	APPR.	DESCRIPTION	FUJITSU DISPLAY TECHNOLOGIES CORPORATION		8 /	
DESIG.			CHECK		APPR.				



Tentative

Note 4) Definition of Response Time

Based on Figure 9-4.

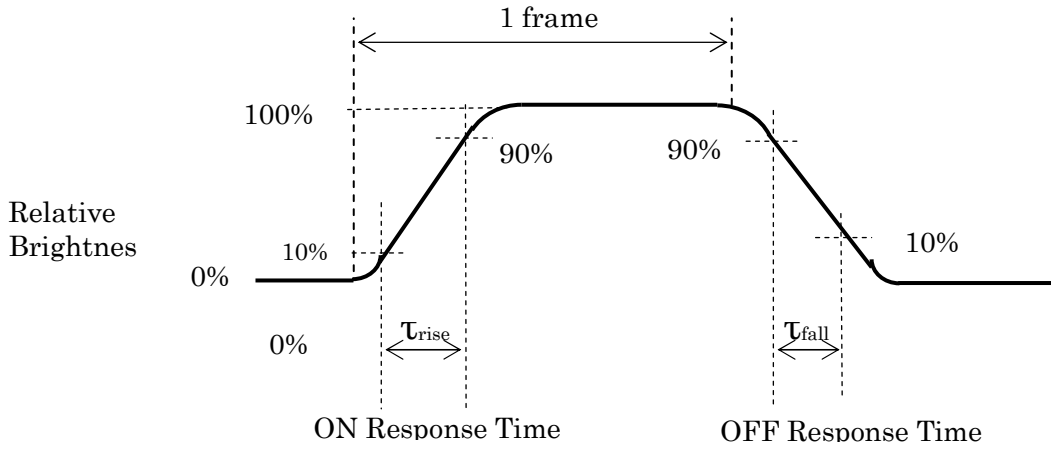

Figure 9-4 Definition of Response Time

Note 5) Contrast Ratio and Response Measurement System

Based on Figure 9-5.

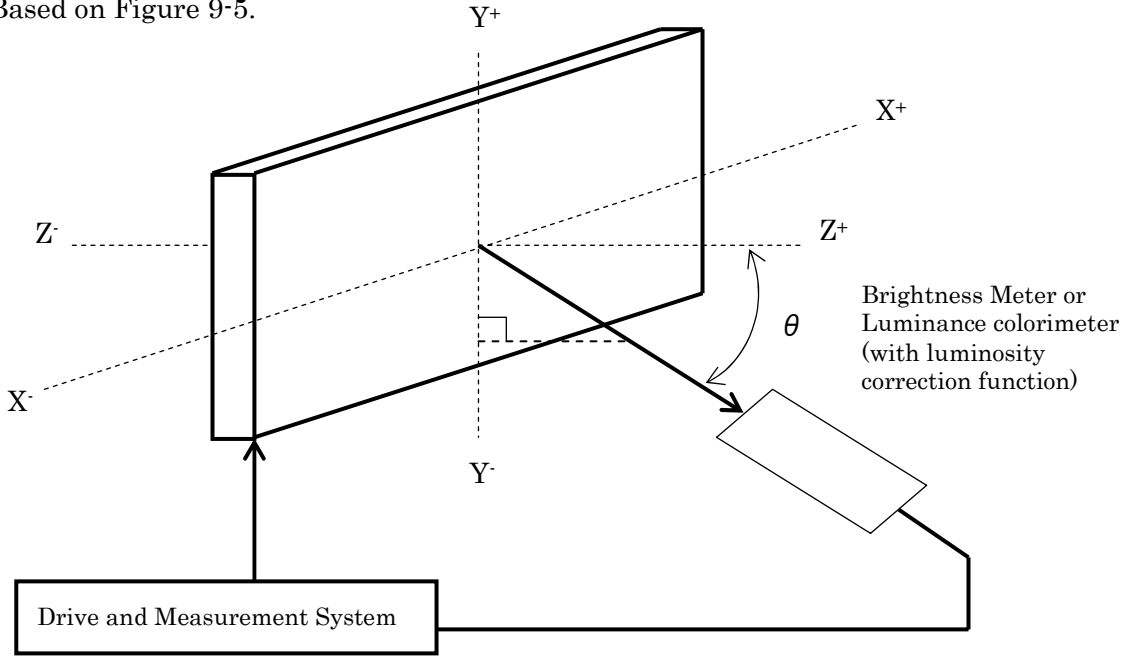

Figure 9-5 Contrast Ratio and Response Time Measurement System

DOCUMENT CONTROL SECTION

						TITLE FLC48SXC8V-12F	
						DRAW. NO. Tech Bes LCD-00287	
						CUST.	
EDIT	DATE	DESIG.	CHECK	APPR.	DESCRIPTION	FUJITSU DISPLAY TECHNOLOGIES CORPORATION	
DESIG.			CHECK	APPR.		10/	

Tentative

Note 6) Definition of Optimum Viewing Angle

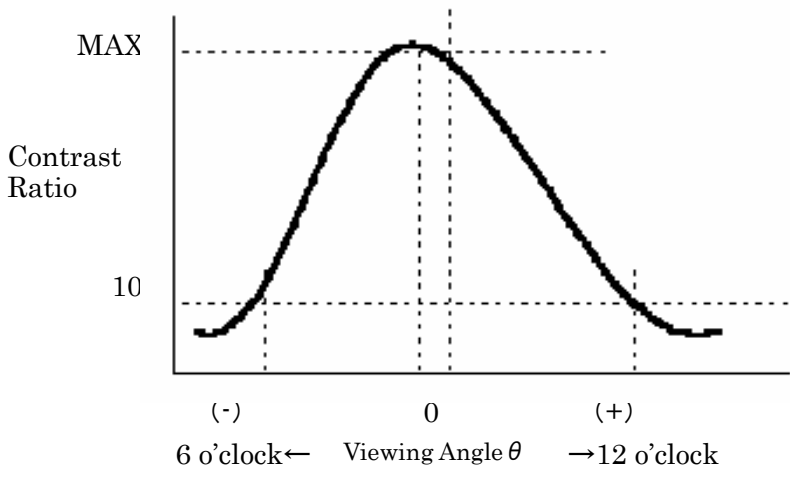
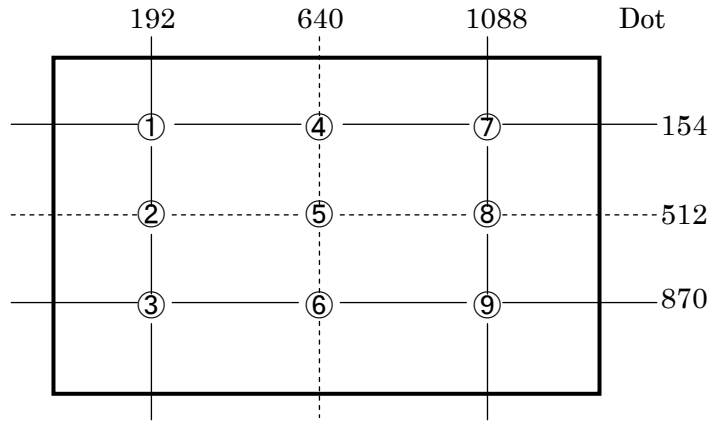

Figure 9-6 Definition of Viewing Angle

Note 7) Definition of Brightness Uniformity

Brightness uniformity is defined by the following formula.  
 Brightness (I1~I9) are measured at the following 9 points (①-⑨) on the display area that is shown in Figure 9-7.

$$\text{Brightness Uniformity } (\Delta L) = \frac{|\text{Min. In }|}{|\text{Max. In }|} \times 100 (\%) , n = 1 \text{ to } 9$$



Note) Each measurement point (①-⑨) defines the center spot of view of Brightness Meter.  
 The tolerance of measurement position is ±3mm.

Figure 9-7 Measurement Points

DATE DOCUMENT CONTROL SECTION

						TITLE		FLC48SXC8V-12F	
						DRAW. NO.			CUST.
						Tech Bes LCD-00287			
EDIT	DATE	DESIG.	CHECK	APPR.	DESCRIPTION				11 /
DESIG.			CHECK	APPR.	FUJITSU DISPLAY TECHNOLOGIES CORPORATION				

Tentative

## 10. INTERFACE SPECIFICATIONS

## 10-1 Signal descriptions

Table 10-1 shows the description and configuration of interface signals (CN1).

Table 10-1 Interface signals (CN1)

Pin No.	Symbol	I/O	Function
1	RxO0-	I	Negative differential input
2	RxO0+	I	Positive differential input
3	RxO1-	I	Negative differential input
4	RxO1+	I	Positive differential input
5	RxO2-	I	Negative differential input
6	RxO2+	I	Positive differential input
7	GND	—	Ground
8	RxOC-	I	Negative differential input
9	RxOC+	I	Positive differential input
10	RxO3-	I	Negative differential input
11	RxO3+	I	Positive differential input
12	RxE0-	I	Negative differential input
13	RxE0+	I	Positive differential input
14	GND	—	Ground
15	RxE1-	I	Negative differential input
16	RxE1+	I	Positive differential input
17	GND	—	Ground
18	RxE2-	I	Negative differential input
19	RxE2+	I	Positive differential input
20	RxEC-	I	Negative differential input
21	RxEC+	I	Positive differential input
22	RxE3-	I	Negative differential input
23	RxE3+	I	Positive differential input
24	GND	—	Ground
25	SEL LVDS	I	Select LVDS Mapping
26	PD	—	LVDS Core Power Down
27	TST	—	Test pin *1
28	Vcc	—	+5V power supply
29	Vcc	—	+5V power supply
30	Vcc	—	+5V power supply

Connector : FI-X30SSL-HF (Japan Aviation Electronics)

User's connector : FI-X30M (FPC type)

FI-X30H (Wire type) , FI-X30HL (Wire with lock)

FI-X30C (Coaxial cable type) , FI-X30C2L (Coaxial cable with lock)

\*1: Keep open. (Internal test use only.)

\*2: When using a connector other than the recommended one , a defect in the initial stage or a problem concerning long term reliability may occur.

DOCUMENT CONTROL SECTION

DATE

						TITLE	FLC48SXC8V-12F	
						DRAW. NO.	Tech Bes LCD-00287	
							CUST.	
EDIT	DATE	DESIG.	CHECK	APPR.	DESCRIPTION	FUJITSU DISPLAY TECHNOLOGIES CORPORATION		12/
	DESIG.		CHECK	APPR.				

Tentative

10-2 LVDS Data Assignment

Table 10-2A,10-2B show the LVDS Data Assignment.

Table 10-2A LVDS Data Assignment(SEL LVDS=L)

Input signal *1		Transmitter DS90CF383,C385		Interface connector			Receiver DS90CF386 THC63LVDF84		LCD Control input			
		pin	INPUT	System side	LCD module		pin	OUTPUT				
					pin							
LVDS Odd	RO2	51	TxIN0	Tx OUT0+	2	RxO0+	27	RxOUT0	RO2			
	RO3	52	TxIN1				29	RxOUT1	RO3			
	RO4	54	TxIN2				30	RxOUT2	RO4			
	RO5	55	TxIN3				32	RxOUT3	RO5			
	RO6	56	TxIN4				33	RxOUT4	RO6			
	RO7	3	TxIN6	Tx OUT0-	1	RxO0-	35	RxOUT6	RO7			
	GO2	4	TxIN7				37	RxOUT7	GO2			
	GO3	6	TxIN8				38	RxOUT8	GO3			
	GO4	7	TxIN9				Tx OUT1+	4	RxO1+	39	RxOUT9	GO4
	GO5	11	TxIN12							43	RxOUT12	GO5
	GO6	12	TxIN13	45	RxOUT13	GO6						
	GO7	14	TxIN14	Tx OUT1-	3	RxO1-				46	RxOUT14	GO7
	BO2	15	TxIN15							47	RxOUT15	BO2
	BO3	19	TxIN18				51	RxOUT18	BO3			
	BO4	20	TxIN19				Tx OUT2+	6	RxO2+	53	RxOUT19	BO4
	BO5	22	TxIN20							54	RxOUT20	BO5
	BO6	23	TxIN21	55	RxOUT21	BO6						
	BO7	24	TxIN22	Tx OUT2-	5	RxO2-				1	RxOUT22	BO7
	RSVD	27	TxIN24							3	RxOUT24	Not use
	RSVD	28	TxIN25				5	RxOUT25	Not use			
	ENAB	30	TxIN26				6	RxOUT26	ENAB			
	RO0	50	TxIN27				Tx OUT3+	11	RxO3+	7	RxOUT27	RO0
	RO1	2	TxIN5	34	RxOUT5	RO1						
	GO0	8	TxIN10	41	RxOUT10	GO0						
	GO1	10	TxIN11	42	RxOUT11	GO1						
BO0	16	TxIN16	Tx OUT3-	10	RxO3-	49				RxOUT16	BO0	
BO1	18	TxIN17				50	RxOUT17	BO1				
RSVD	25	TxIN23				2	RxOUT23	Not use				
DCLK	31	TxCLK IN				TxCLK OUT+	9	RxCLK IN+	26	RxCLK OUT	DCLK	
						TxCLK OUT-	8	RxCLK IN-				
LVDS Even	RE2	51	TxIN0	Tx OUT0+	13	RxEO+	27	RxOUT0	RE2			
	RE3	52	TxIN1				29	RxOUT1	RE3			
	RE4	54	TxIN2				30	RxOUT2	RE4			
	RE5	55	TxIN3				32	RxOUT3	RE5			
	RE6	56	TxIN4				33	RxOUT4	RE6			
	RE7	3	TxIN6	Tx OUT0-	12	RxEO-	35	RxOUT6	RE7			
	GE2	4	TxIN7				37	RxOUT7	GE2			
	GE3	6	TxIN8				Tx OUT1+	16	RxE1+	38	RxOUT8	GE3
	GE4	7	TxIN9							39	RxOUT9	GE4
	GE5	11	TxIN12							43	RxOUT12	GE5
	GE6	12	TxIN13	45	RxOUT13	GE6						
	GE7	14	TxIN14	Tx OUT1-	15	RxE1-				46	RxOUT14	GE7
	BE2	15	TxIN15				47	RxOUT15	BE2			
	BE3	19	TxIN18				Tx OUT2+	19	RxE2+	51	RxOUT18	BE3
	BE4	20	TxIN19							53	RxOUT19	BE4
	BE5	22	TxIN20							54	RxOUT20	BE5
	BE6	23	TxIN21	55	RxOUT21	BE6						
	BE7	24	TxIN22	Tx OUT2-	18	RxE2-				1	RxOUT22	BE7
	RSVD	27	TxIN24				3	RxOUT24	Not use			
	RSVD	28	TxIN25				5	RxOUT25	Not use			
	RSVD	30	TxIN26				6	RxOUT26	Not use			
	RE0	50	TxIN27				Tx OUT3+	23	RxE3+	7	RxOUT27	RE0
	RE1	2	TxIN5	34	RxOUT5	RE1						
	GE0	8	TxIN10	41	RxOUT10	GE0						
	GE1	10	TxIN11	42	RxOUT11	GE1						
BE0	16	TxIN16	Tx OUT3-	22	RxE3-	49				RxOUT16	BE0	
BE1	18	TxIN17				50	RxOUT17	BE1				
RSVD	25	TxIN23				2	RxOUT23	Not use				
DCLK	31	TxCLK IN				TxCLK OUT+	21	RxCLK IN+	26	RxCLK OUT	Not use	
						TxCLK OUT-	20	RxCLK IN-				

\*1 ·RSVD (reserved) pin on a transmitter should be connected with Ground.  
·Input odd or even data depending on the display position of the LCD module.

DOCUMENT CONTROL SECTION

DATE

						TITLE		FLC48SXC8V-12F	
						DRAW. NO.			CUST.
						Tech Bes LCD-00287			
EDIT	DATE	DESIG.	CHECK	APPR.	DESCRIPTION				FUJITSU DISPLAY TECHNOLOGIES CORPORATION
			CHECK			APPR.		13/	

Tentative

**Table 10-2B LVDS Data Assignment(SEL LVDS=H)**

Input signal *1		Transmitter DS90CF383,C385		Interface connector			Receiver DS90CF386 THC63LVDF84		LCD Control input
		pin	INPUT	System side	LCD module		pin	OUTPUT	
					pin				
LVDS Odd	RO0	51	TxIN0	Tx OUT0+	2	RxO0+	27	RxOUT0	RO0
	RO1	52	TxIN1				29	RxOUT1	RO1
	RO2	54	TxIN2				30	RxOUT2	RO2
	RO3	55	TxIN3				32	RxOUT3	RO3
	RO4	56	TxIN4				33	RxOUT4	RO4
	RO5	3	TxIN6	Tx OUT0-	1	RxO0-	35	RxOUT6	RO5
	GO0	4	TxIN7				37	RxOUT7	GO0
	GO1	6	TxIN8				38	RxOUT8	GO1
	GO2	7	TxIN9				39	RxOUT9	GO2
	GO3	11	TxIN12				43	RxOUT12	GO3
	GO4	12	TxIN13	Tx OUT1-	3	RxO1-	45	RxOUT13	GO4
	GO5	14	TxIN14				46	RxOUT14	GO5
	BO0	15	TxIN15				47	RxOUT15	BO0
	BO1	19	TxIN18				51	RxOUT18	BO1
	BO2	20	TxIN19				53	RxOUT19	BO2
	BO3	22	TxIN20	Tx OUT2+	6	RxO2+	54	RxOUT20	BO3
	BO4	23	TxIN21				55	RxOUT21	BO4
	BO5	24	TxIN22				1	RxOUT22	BO5
	RSVD	27	TxIN24				3	RxOUT24	Not use
	RSVD	28	TxIN25				5	RxOUT25	Not use
	ENAB	30	TxIN26	6	RxOUT26	ENAB			
	RO6	50	TxIN27	Tx OUT2-	5	RxO2-	7	RxOUT27	RO6
	RO7	2	TxIN5				34	RxOUT5	RO7
	GO6	8	TxIN10				41	RxOUT10	GO6
	GO7	10	TxIN11				42	RxOUT11	GO7
BO6	16	TxIN16	49				RxOUT16	BO6	
BO7	18	TxIN17	Tx OUT3-	10	RxO3-	50	RxOUT17	BO7	
RSVD	25	TxIN23				2	RxOUT23	Not use	
DCLK		31	TxCLK IN	TxCLK OUT+	9	RxCLK IN+	26	RxCLK OUT	DCLK
				TxCLK OUT-	8	RxCLK IN-			
LVDS Even	RE0	51	TxIN0	Tx OUT0+	13	RxE0+	27	RxOUT0	RE0
	RE1	52	TxIN1				29	RxOUT1	RE1
	RE2	54	TxIN2				30	RxOUT2	RE2
	RE3	55	TxIN3				32	RxOUT3	RE3
	RE4	56	TxIN4				33	RxOUT4	RE4
	RE5	3	TxIN6	Tx OUT0-	12	RxE0-	35	RxOUT6	RE5
	GE0	4	TxIN7				37	RxOUT7	GE0
	GE1	6	TxIN8				38	RxOUT8	GE1
	GE2	7	TxIN9				39	RxOUT9	GE2
	GE3	11	TxIN12				43	RxOUT12	GE3
	GE4	12	TxIN13	Tx OUT1-	15	RxE1-	45	RxOUT13	GE4
	GE5	14	TxIN14				46	RxOUT14	GE5
	BE0	15	TxIN15				47	RxOUT15	BE0
	BE1	19	TxIN18				51	RxOUT18	BE1
	BE2	20	TxIN19				53	RxOUT19	BE2
	BE3	22	TxIN20	Tx OUT2+	19	RxE2+	54	RxOUT20	BE3
	BE4	23	TxIN21				55	RxOUT21	BE4
	BE5	24	TxIN22				1	RxOUT22	BE5
	RSVD	27	TxIN24				3	RxOUT24	Not use
	RSVD	28	TxIN25				5	RxOUT25	Not use
	RSVD	30	TxIN26	6	RxOUT26	Not use			
	RE6	50	TxIN27	Tx OUT2-	18	RxE2-	7	RxOUT27	RE6
	RE7	2	TxIN5				34	RxOUT5	RE7
	GE6	8	TxIN10				41	RxOUT10	GE6
	GE7	10	TxIN11				42	RxOUT11	GE7
BE6	16	TxIN16	Tx OUT3+				23	RxE3+	49
BE7	18	TxIN17		50	RxOUT17	BE7			
RSVD	25	TxIN23		2	RxOUT23	Not use			
DCLK		31	TxCLK IN	TxCLK OUT+	21	RxCLK IN+	26	RxCLK OUT	Not use
				TxCLK OUT-	20	RxCLK IN-			

\*1 •RSVD (reserved) pin on a transmitter should be connected with Ground.  
 •Input odd or even data depending on the display position of the LCD module.

DOCUMENT CONTROL SECTION

DATE

						TITLE		FLC48SXC8V-12F	
						DRAW. NO.			CUST.
						Tech Bes LCD-00287			
EDIT	DATE	DESIG.	CHECK	APPR.	DESCRIPTION		FUJITSU DISPLAY TECHNOLOGIES CORPORATION		14/
DESIG.			CHECK		APPR.				

**10-3 Color Data Assignment**

Table 10-3 shows the Color Data Assignment.

**Table 10-3 Color Data Assignment**

Color		R Input data								G Input data								B Input data								
		R7	R6	R5	R4	R3	R2	R1	R0	G7	G6	G5	G4	G3	G2	G1	G0	B7	B6	B5	B4	B3	B2	B1	B0	
Basic Color	Black	0	0	0	0	0	0	0	0	0	0	0	0	0	0	0	0	0	0	0	0	0	0	0	0	
	Blue	0	0	0	0	0	0	0	0	0	0	0	0	0	0	0	0	1	1	1	1	1	1	1	1	
	Green	0	0	0	0	0	0	0	0	1	1	1	1	1	1	1	1	0	0	0	0	0	0	0	0	
	Cyan	0	0	0	0	0	0	0	0	1	1	1	1	1	1	1	1	1	1	1	1	1	1	1	1	
	Red	1	1	1	1	1	1	1	1	0	0	0	0	0	0	0	0	0	0	0	0	0	0	0	0	
	Magenta	1	1	1	1	1	1	1	1	0	0	0	0	0	0	0	0	1	1	1	1	1	1	1	1	
	Yellow	1	1	1	1	1	1	1	1	1	1	1	1	1	1	1	1	0	0	0	0	0	0	0	0	
	White	1	1	1	1	1	1	1	1	1	1	1	1	1	1	1	1	1	1	1	1	1	1	1	1	
Red	Black	0	0	0	0	0	0	0	0	0	0	0	0	0	0	0	0	0	0	0	0	0	0	0	0	
	↑	1	0	0	0	0	0	0	0	1	0	0	0	0	0	0	0	0	0	0	0	0	0	0	0	0
	↑	:	:	:	:	:	:	:	:	:	:	:	:	:	:	:	:	:	:	:	:	:	:	:	:	
	↓	:	:	:	:	:	:	:	:	:	:	:	:	:	:	:	:	:	:	:	:	:	:	:	:	
	Brighter	253	1	1	1	1	1	1	0	1	0	0	0	0	0	0	0	0	0	0	0	0	0	0	0	0
	↓	254	1	1	1	1	1	1	1	0	0	0	0	0	0	0	0	0	0	0	0	0	0	0	0	0
	Red	255	1	1	1	1	1	1	1	1	0	0	0	0	0	0	0	0	0	0	0	0	0	0	0	0
Green	Black	0	0	0	0	0	0	0	0	0	0	0	0	0	0	0	0	0	0	0	0	0	0	0	0	
	↑	1	0	0	0	0	0	0	0	0	0	0	0	0	0	0	0	1	0	0	0	0	0	0	0	0
	↑	:	:	:	:	:	:	:	:	:	:	:	:	:	:	:	:	:	:	:	:	:	:	:	:	
	↓	:	:	:	:	:	:	:	:	:	:	:	:	:	:	:	:	:	:	:	:	:	:	:	:	
	Brighter	253	0	0	0	0	0	0	0	0	1	1	1	1	1	1	0	1	0	0	0	0	0	0	0	0
	↓	254	0	0	0	0	0	0	0	0	1	1	1	1	1	1	1	0	0	0	0	0	0	0	0	0
	Green	255	0	0	0	0	0	0	0	0	1	1	1	1	1	1	1	1	0	0	0	0	0	0	0	0
Blue	Black	0	0	0	0	0	0	0	0	0	0	0	0	0	0	0	0	0	0	0	0	0	0	0	0	
	↑	1	0	0	0	0	0	0	0	0	0	0	0	0	0	0	0	0	0	0	0	0	0	0	0	1
	↑	:	:	:	:	:	:	:	:	:	:	:	:	:	:	:	:	:	:	:	:	:	:	:	:	
	↓	:	:	:	:	:	:	:	:	:	:	:	:	:	:	:	:	:	:	:	:	:	:	:	:	
	Brighter	253	0	0	0	0	0	0	0	0	0	0	0	0	0	0	0	0	1	1	1	1	1	1	0	1
	↓	254	0	0	0	0	0	0	0	0	0	0	0	0	0	0	0	0	1	1	1	1	1	1	1	0
	Blue	255	0	0	0	0	0	0	0	0	0	0	0	0	0	0	0	0	1	1	1	1	1	1	1	1

Note.1) Definition of gray scale:Color (n)...”n” indicates gray scale level.

Larger number means brighter level.

Note.2) Data: 1:High, 0:Low

Note 3) Color data consist of 8 bit red, green and blue data of odd and even number pixel data.

Total data number is 48 signals. This module is able to display 16,777,216 colors because each red, green and blue data is controlled independently.

DOCUMENT CONTROL SECTION

						TITLE		FLC48SXC8V-12F			
						DRAW. NO.			CUST.		
						Tech Bes LCD-00287					
EDIT	DATE	DESIG.	CHECK	APPR.	DESCRIPTION					FUJITSU DISPLAY TECHNOLOGIES CORPORATION	15/



Tentative

10-4 Input Signal Timing

Table 10-4 and Figure 10-1 shows the Input Signal Timing at LVDS transmitter.

Table 10-4 Timing Characteristics

(Ta=0~50°C, Vcc=5±0.25V)

Item	Symbol	Min.	Typ.	Max.	Unit	Remark		
DCLK signal (Clock)	Period	Tc	14.3	18.5	25.0	ns		
	Frequency	1/Tc	40	54	70	MHz		
	Duty	Tch/Tc	45	50	55	%		
	High time	TelkH	5.0	—	—	ns		
	Low time	TelkL	5.0	—	—	ns		
DCLK-Data Timing	Setup time	Tset	3	—	—	ns	LVDS Tr spec.	
	Hold time	Tthold	5	—	—	ns		
ENAB signal	Hor. Period (1)	Th	680	844	887 *1	DCLK		
	Hor. Period (1)	Th	12.5	15.6	—	μs		
	Hor. Period (2)	Th	648	—	1023	DCLK		*4
	Hor. Display period	Thd	640	640	640	DCLK		*2
	Vertical Period	Tv	1028 *1	1066	1088 *1	Th		16.67ms
	Ver. Frequency	1/Tv	50	60	76.2	Hz		
	Ver. Display period	Tvd	1024	1024	1024	Th		*2
Data-ENAB timing	Tdn	—	0	—	DCLK	*3		

\*1) horizontal display position is specified by the rise of ENAB.

The data latched at falling edge of DCLK after rise of ENAB is displayed at the left edge of the display area.

Vertical display position is specified by the rise of ENAB after low level continuation over 2048 DCLK.

The data latched at the rise of ENAB is displayed at the top line of the display area.

\*2) If the “High” level period of ENAB is less than 640 DCLK or the number of ENAB in a frame period (Tv) is less than 1024, black color is displayed at the rest of the display area.

\*3) If ENAB does not synchronize with the effective display data, the display position does not fit to the display area.

\*4) Hor. Period (2) shows the operating range where internal circuit can work correctly. When ENAB signal is out of Hor. Period (1), the display quality may deteriorate.

DOCUMENT CONTROL SECTION

DATE

						TITLE		FLC48SXC8V-12F			
						DRAW. NO.			CUST.		
						Tech Bes LCD-00287					
EDIT	DATE	DESIG.	CHECK	APPR.	DESCRIPTION					FUJITSU DISPLAY TECHNOLOGIES CORPORATION	16/

Tentative

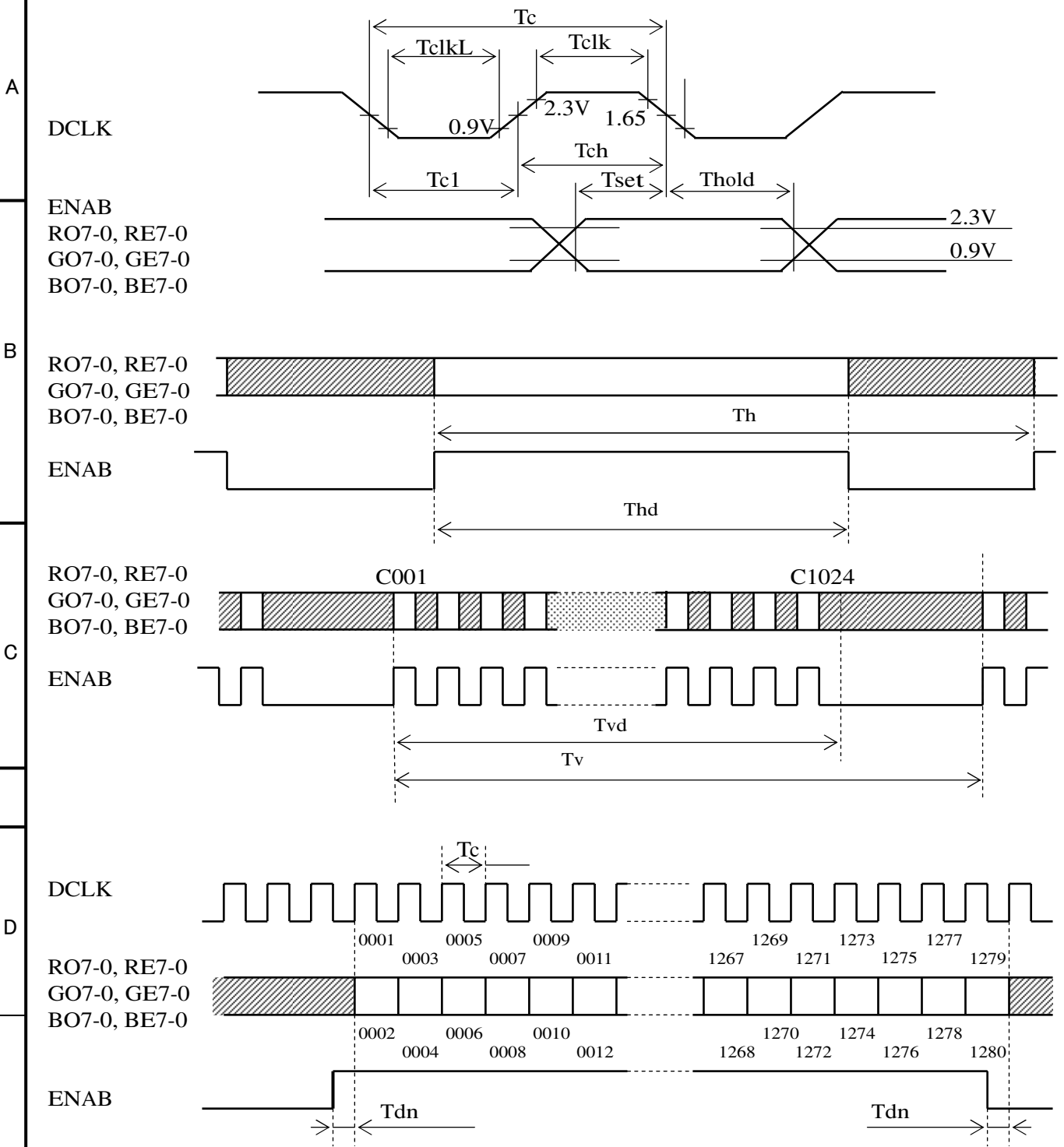

Figure 10-1 Input Signal Timing Chart

DOCUMENT CONTROL SECTION

DATE

						TITLE FLC48SXC8V-12F	
						DRAW. NO. Tech Bes LCD-00287	
						CUST.	
EDIT	DATE	DESIG.	CHECK	APPR.	DESCRIPTION		
DESIG.			CHECK		APPR.	FUJITSU DISPLAY TECHNOLOGIES CORPORATION	
						17/	



Tentative

## 11. BACK-LIGHT SPECIFICATIONS

### 11-1 Pin configuration for Back-light

Table 11-1 shows the description and Pin assignment of the connectors (CN-A to F) for the Back-light of this LCD module.

Table 11-1 Pin Assignment of CN-A to CN-F

Pin No.	Signal						Function	Cable color
	CN-A	CN-B	CN-C	CN-D	CN-E	CN-F		
1	V <sub>L1</sub>	V <sub>L2</sub>	V <sub>L3</sub>	V <sub>L4</sub>	V <sub>L5</sub>	V <sub>L6</sub>	Power supply	Pink, Red, Orange
2	—	—	—	—	—	—	—	—
3	GND	GND	GND	GND	GND	GND	Ground	Aqua, White, Black

Connector : Housing : BDBR-03(4.0)V-S  
 Contact : SBH-001T-P0.5  
 User's Connector : Post with base: SM02(8.0)B-BDBS-1  
 SM02(8.0)B-BHS-1-TB

Supplier : Japan Solderless Terminal Trading Company LTD. (J.S.T.)

### 11-2 Life

The life of the back-light is a minimum of 50,000 hours at the following conditions.

#### (1) Working conditions

- ① Ambient temperature:  $25 \pm 5^\circ\text{C}$
- ② Tube current (I<sub>L</sub>) : 7mA or less

#### (2) Definition of life

- ① Brightness becomes 50% or less than the minimum brightness value shown in Table 9-1.
- ② The lamp cannot be lit by the minimum value of the breakdown voltage(1760Vrms) shown in Table 8-1.
- ③ Flashing.

### 11-3 Lamp assembly set (for replacement)

Lamp assembly set(with charge)is prepared for replacing old lamp to new one.  
 This set consists of a upper lamp assembly and a lower lamp assembly.

Type number : FLCL-40

Minimum order qty. unit : 20 pcs.

DOCUMENT CONTROL SECTION

DATE

						TITLE	FLC48SXC8V-12F	
						DRAW. NO.	Tech Bes LCD-00287	CUST.
EDIT	DATE	DESIG.	CHECK	APPR.	DESCRIPTION	FUJITSU DISPLAY TECHNOLOGIES CORPORATION	19/	F
DESIG.			CHECK		APPR.			

Tentative

12. APPEARANCE SPECIFICATIONS

12-1 Appearance

No.	Item	Judgment method and standard		
1	Bright spot (high and Low)	$\leq 4$ dots		(Note 1)
2	Bright spot connection (high and low)	$\leq 2$ pair (2 dot connection in horizontal only)		(Note 1)
3	Total of bright spot	$\leq 4$ dots		
4	Dark spot	$\leq 8$ dots		(Note 2)
5	Dark spot connection	$\leq 3$ pairs		(Note 2)
6	Total of dark spot	$\leq 8$ dots		(Note 2)
7	Total of dot defect (bright and dark)	$\leq 8$ dots		
8	Distance of bright spot	high-hgh	$\geq 15$ mm	
		others	$\geq 5$ mm	
9	Distance of dark spot	$\geq 5$ mm		
10	Scratch on polarizer, line shape	$W \leq 0.03$	-----	Ignore
		$0.03 < W \leq 0.05$	$L \leq 6$	Ignore
			$6 < L \leq 12$	$\leq 5$
		$0.05 < W \leq 0.10$	$12 < L$	0
			$L \leq 0.6$	Ignore
$0.10 < W$	-----	0		
11	Dent on polarizer, dot shape	$D \leq 0.3$		Ignore
		$0.3 < D \leq 0.4$		$\leq 5$
		$0.4 < D$		0
12	Bubble in polarizer	$D \leq 0.3$		Ignore
		$0.3 < D \leq 0.5$		$\leq 5$
		$0.5 < D$		0
13	Black white spot (Foreign circular matter)	$D \leq 0.3$		Ignore
		$0.3 < D \leq 0.5$		$\leq 5$
		$0.5 < D$		0
14	Light leakage by foreign articles	$D \leq 0.3$		Ignore
		$0.3 < D \leq 0.6$		$\leq 4$
		$0.6 < D$		0
15	Lints, black/white line	$W \leq 0.03$	-----	Ignore
		$0.03 < W \leq 0.05$	$L \leq 6$	Ignore
			$6 < L \leq 12$	$\leq 4$
		$0.05 < W \leq 0.10$	$12 < L$	0
			$L \leq 0.6$	Ignore
$0.10 < W$	$0.6 < L \leq 5$	$\leq 2$		
		$5 < L$	0	
		$(W+L)/2=D$		Conform to No.13
16	Mura	Invisible under 6% ND filter from center of display. (Display pattern : Black, White, 50% gray)		

D:Average diameter [mm], W:Width [mm], L:Length [mm], S=(bright spot size)/(dot size)

DOCUMENT CONTROL SECTION

DATE

						TITLE FLC48SXC8V-12F	
						DRAW. NO. Tech Bes LCD-00287	
						CUST.	
EDIT	DATE	DESIG.	CHECK	APPR.	DESCRIPTION FUJITSU DISPLAY TECHNOLOGIES CORPORATION		
DESIG.			CHECK		APPR.		20/

12-2 Dot defects (Bright spots, Dark spots)

12-2-1 Zone

- Inside display dot area (376.32×301.056mm)
- Display dot area means active area.
- One pixel consists of 3 dots (red, green and blue).
- Foreign particle and scratch unharmed to display image, such as the foreign particle under polarizer film but outside of the display area and scratch on metal bezel, backlight module or polarizer film out of the display area, etc., are not counted.

12-2-2 Bright spots

- (1) Bright spots by the defect of TFT.
- Visible under bias of 2% ND filter ..... High bright spot R•G
  - Visible under 5% but invisible under 2% ND filter ..... Low bright spot R•G•B
  - Invisible under bias of 5% ND filter ..... Not counted
- (2) Bright spots by the light passing through tears, breaks, etc in color filter.
- Exceed size of a half dot ..... High bright spot
  - A half dot or less ..... Not counted
- (3) Bright spots by the light passing through tears, breaks, etc in chromium mask.
- Exceed 50μm..... High bright spot
  - 50μm or less ..... Not counted

12-2-3 Test condition

- Inspector must observe the LCD screen from the normal direction under the illumination by a single 20W fluorescent lamp. The distance between the LCD screen and the inspector should be a height of 50cm above the worktable.  
The vertical illuminance is 300 to 600lux (reference value).
- Bright spot should be counted under entire black screen.
- Dark spot should be counted under entire white screen.
- Input signal timing should be typical value.

(Note1) Please do not mistake a single bright spot for a bright spot connection due to Cs(supplemental capacitance) line at the center of each dot.

(Note2) If a pixel is dark partially, it connects into the number of dark spots in accordance with following rule.

- (a)  $A < 1/3$  : Not count. Only one of 4 dark connection is allowed.
  - (b)  $1/3 \leq A < 2/3$  : Considered as 0.5 dot.
  - (c)  $2/3 \leq A$  : Considered as 1 dot.
- (A=Dark spot size/dot size)

DOCUMENT CONTROL SECTION

						TITLE FLC48SXC8V-12F	
						DRAW. NO. Tech Bes LCD-00287	
						CUST.	
EDIT	DATE	DESIG.	CHECK	APPR.	DESCRIPTION	FUJITSU DISPLAY TECHNOLOGIES CORPORATION	
DESIG.			CHECK		APPR.	21/	

Tentative

### 13. ENVIRONMENTAL SPECIFICATIONS

Table 13-1 show the environmental specifications.

Table 13-1 Environmental specifications

Item	Condition		Remark
Temperature	Operation	0~50°C	Temperature on surface of LCD panel (display area.)
	Storage	-20~60°C	
Humidity	Operation	20~85%RH	Maximum wet-bulb temperature should not exceed 29°C. No condensation.
	Storage	5~85%RH	
Vibration	Non-operation	10~500Hz, 1octave/ 20minute, 19.6m/s <sup>2</sup> (2G), 1.5mm max, 1hour each X, Y and Z directions.	For single module without package.
Shock *1	Non-operation	294m/s <sup>2</sup> (30G), 6ms, 1time each ±X, ±Y and ±Z directions.	

NOTE: Table 13-2 and Figure 13-1 show the shock resistance standard when module is packaged.

Table 13-2 Shock resistance standard when module is packaged

Dropping location	Dropping height	Count
A~J	60cm	1 time

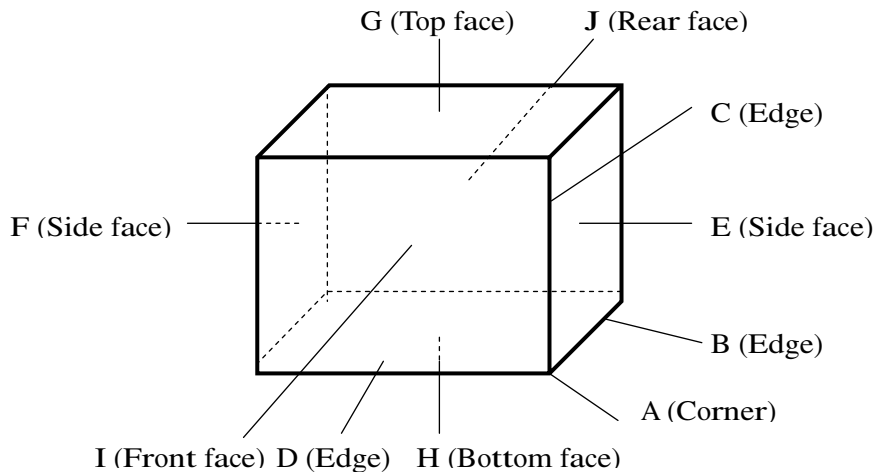

Figure 13-1 Direction to apply shock to package

DOCUMENT CONTROL SECTION

						TITLE		FLC48SXC8V-12F	
						DRAW. NO.		Tech Bes LCD-00287	
								CUST.	
EDIT	DATE	DESIG.	CHECK	APPR.	DESCRIPTION				
DESIG.			CHECK		FUJITSU DISPLAY TECHNOLOGIES CORPORATION				
								22/	

### 14. INDICATIONS

This module has the following indications.

- (1) Product name : **LCD unit**
- (2) Model Number : **FLC48SXC8V-12F**
- (3) Product Drawing Number : **NA19026-C292**
- (4) Manufacturing Number : **4 8 0 0 0 0 1**

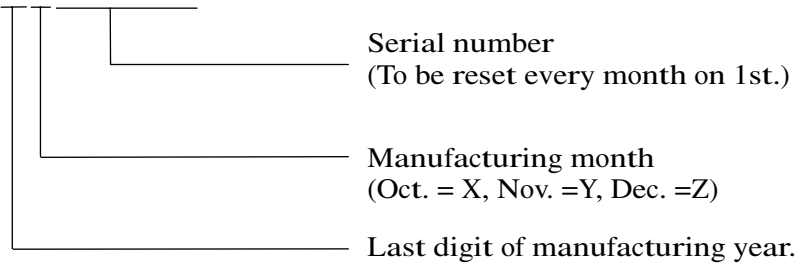

- (5) Version number : **01A** (Example)  
-1st 2 digits "01" means operational version.  
-3rd alphabet means functional version.
- (6) Manufacturer Country Name :
- (7) Company Name : **FUJITSU DISPLAY TECHNOLOGIES CORP.**
- (8) Disposal method of cold-cathode tubes.
- (9) Caution when changing cold-cathode tubes.

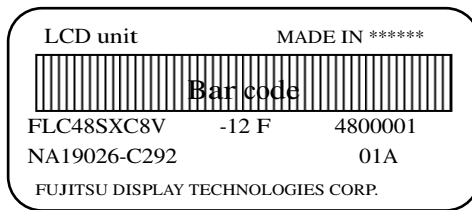

Figure 14-1 Product Label (Example)

### 15. PACKAGING

#### 15-1 Packing specifications

- (1) 5 LCD modules/1package.
- (2) Weight : approximately 16kg /1package.
- (3) Outline dimensions: 499mm (W)x 250mm (D)x 464mm (H)

#### 15-2 Packing method

Figure 15-2 show the packing method.

DATE      DOCUMENT CONTROL SECTION

						TITLE		FLC48SXC8V-12F	
						DRAW. NO.			CUST.
						Tech Bes LCD-00287			
EDIT	DATE	DESIG.	CHECK	APPR.	DESCRIPTION		FUJITSU DISPLAY TECHNOLOGIES CORPORATION		23 /
	DESIG.		CHECK		APPR.				









Tentative

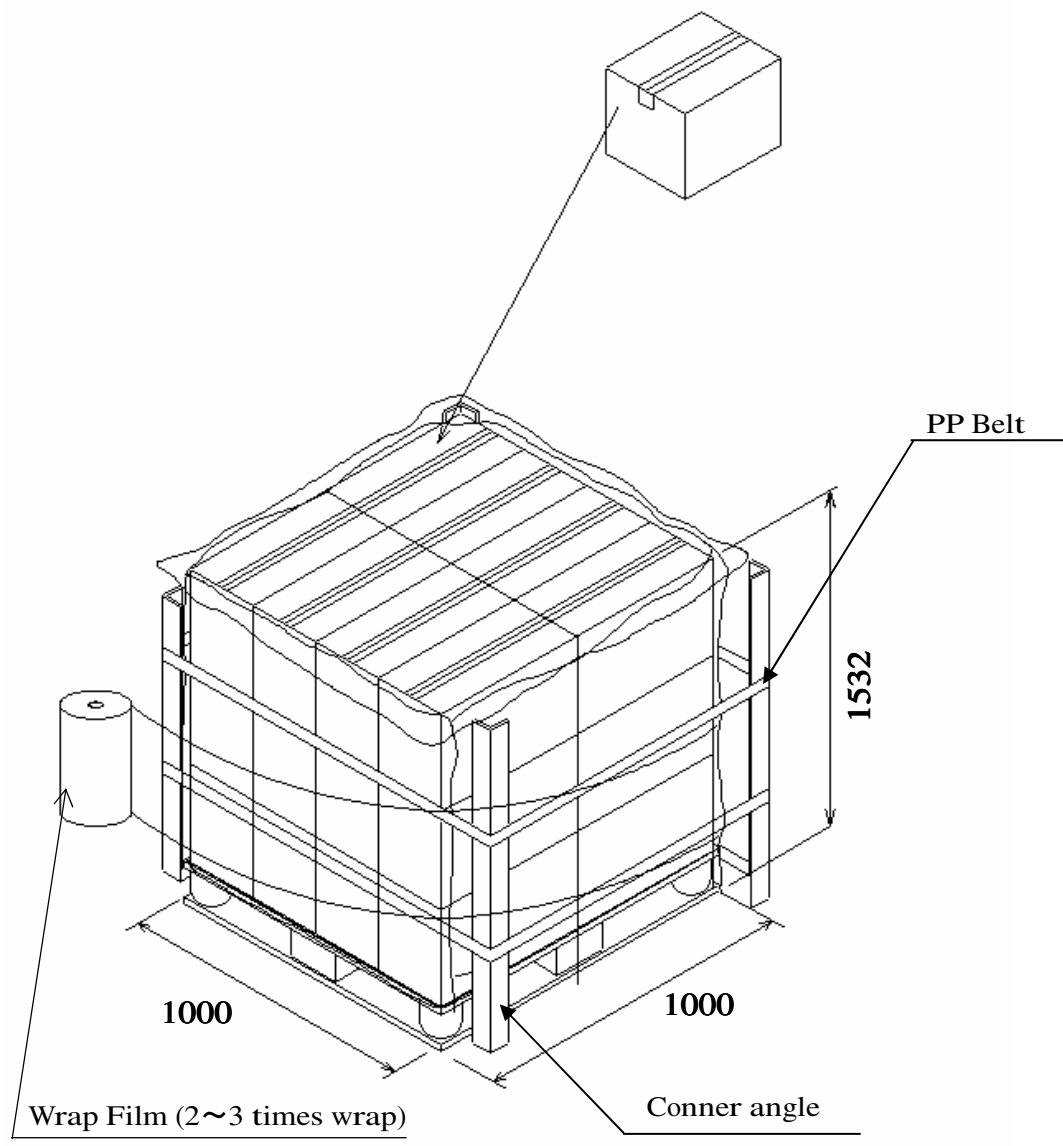

Carton Qty./ pallet : 8 boxes × 3 layers (maximum 24 boxes)

Fig.15-2 (c) Packaging Method

DOCUMENT CONTROL SECTION

						TITLE		FLC48SXC8V-12F	
						DRAW. NO.			CUST.
						Tech Bes LCD-00287			
EDIT	DATE	DESIG.	CHECK	APPR.	DESCRIPTION				FUJITSU DISPLAY TECHNOLOGIES CORPORATION
									27 /

Tentative

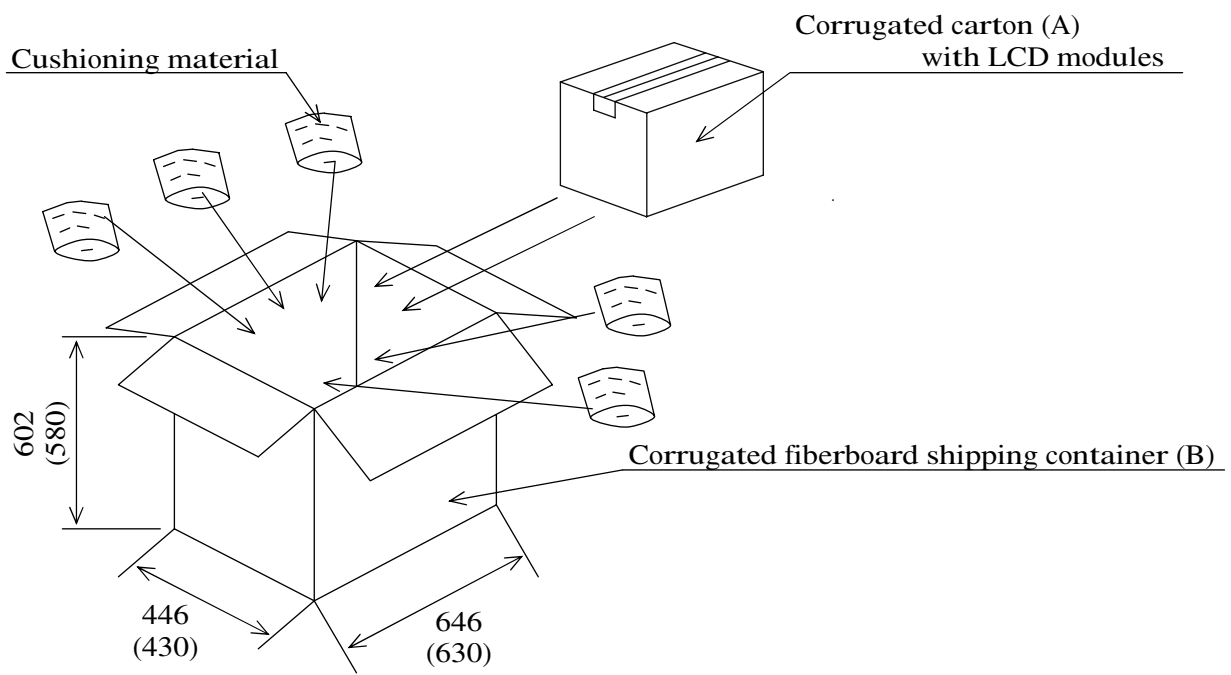

Note 1) The carton (A) should be placed in the middle of the container (B) with enough cushioning materials.

Note2) The figures in ( ) show inside measurements of the container (B).

Figure.15-2 (d) Packing method

DOCUMENT CONTROL SECTION

						TITLE		FLC48SXC8V-12F	
						DRAW. NO.			CUST.
						Tech Bes LCD-00287			
EDIT	DATE	DESIG.	CHECK	APPR.	DESCRIPTION				FUJITSU DISPLAY TECHNOLOGIES CORPORATION
DESIG.			CHECK			APPR.		28 /	

**16.WARRANTY**

The warranty period is one year after shipping. Products which fail during this period are repaired or replaced without charge, unless the failure is caused by user.

**17.PRECAUTIONS**

Adhere to the following precautions to use this LCD module properly.

**(1) Fail safe design**

LCD module has an inherent chance of failure. Customers must protect against injury, damage or loss from such failures by incorporating safety design measures into your facility and equipment such as redundancy, fire protection, and prevention of over-current levels and other abnormal operating conditions.

**(2) Handling of LCD panel**

**① Do not apply any strong mechanical shock to the LCD panel.**

Since the LCD panel is made of glass, excessive shock may damage the panel or cause a malfunction.

**② Do not press hard on the LCD panel surface.**

In the LCD panel, the gap between two glass plates is kept perfectly even to maintain display properties and reliability. The hard pressure on the LCD panel may cause the following problems. If the pressure is over 2kg/cm<sup>2</sup>, the problem don't return to normal condition.

- ① Ununiformity of color
- ② Disorder of orientation of liquid crystal

Problem ① returns to normal condition after a while. Problem ② returns to normal condition by turning the power off and turning on again. However these operations should be avoided to insure reliability.

**③ Do not scratch the polarizer film on the LCD panel surface.**

- Do not press or rub the display surface with a hard tool, tweezers, etc.
- For handling, use cotton or conductive gloves so that the display surface is not soiled.
- If dust or dirt soils the display surface, clean it as follows with a soft cloth (deerskin, etc.)

[Dust] Wipe off with a soft cloth. (do not rub.)

[Dirt ] Apply clear water to a soft cloth and squeeze hard out of water drops, then lightly wipe off the specified parts. Only if the dirt is hardly wiped off, use isopropyl alcohol or ethanol.

Be careful not to splash the water or the solvents on the edge of polarizer and in the LCD unit.

The polarizer possibly exfoliates due to the solvent and water penetrated between the polarizer and the LCD panel.

Do not use unspecified solvent such as ketone (acetone, etc.) and aromatics (xylene, toluene, etc.)

DATE DOCUMENT CONTROL SECTION

						TITLE		FLC48SXC8V-12F	
						DRAW. NO.		Tech Bes LCD-00287	
								CUST.	
EDIT	DATE	DESIG.	CHECK	APPR.	DESCRIPTION				
DESIG.			CHECK		APPR.	FUJITSU DISPLAY TECHNOLOGIES CORPORATION		29 /	

**Tentative**

(Caution) Be careful not to allow the water or solvent to enter the module.

•If saliva or water drops are left for a long period of time, the part may become deformed or discolored.

Wipe off immediately in the same way as for dirt.

•Do not allow oil to adhere to the module since excessive oil is hard to clean.

**④ Do not place or contact objects on the display surface for a long period of time.**

This may make some parts of the LCD module distorted and the quality of display may deteriorate.

**(3) Handling of LCD module**

**① Do not pull the cold-cathode tube cable strongly.**

If the cable is pulled with the strength of 2kg or more, the cable may be damaged or may lose reliability.

**② Assemble the module into user's system in a dust free environment.**

Conductive foreign matter adheres to the module may cause failures.

**③ Take anti-electrostatic measures for assembling the module.**

Since the LCD module contains CMOS-ICs, the following points should be observed.

•For assembling the module, operator should be grounded and wear cotton or conductive gloves.

•Floor of work area and work table to assemble the LCD module should be covered with electrostatic shielding in order to discharge static electricity via an earth wire.

•If necessary, ground operation tools (soldering iron, radio pliers, tweezers, etc.).

•Do not take the module out of the conductive bag until the module is assembled.

•Do not assemble the module under low humidity (50%RH or less).

**④ Do not pull the connecting cable on the rear face of the LCD module strongly.**

**⑤ Do not disassemble or remodel the LCD module.**

Disassembly or remodeling of the LCD module may result in malfunctions or deterioration of the display quality and reliability.

**(4) Precautions in regards of operating the LCD module**

**① Adhere to the specified power supply sequence.**

If not followed, the CMOS-IC may cause a latch-up, or DC voltage may be applied to the liquid crystal, which cause a failure or serious deterioration in display quality.

**② Do not operate the LCD module when condensation occurs.**

If the LCD module is operated when condensation is on the terminals of the LCD panel, the terminals cause electrochemical reaction, and may reach disconnection. Condensation easily occurs especially when the module is moved from cold environment to warm environment.

DATE DOCUMENT CONTROL SECTION

						TITLE		FLC48SXC8V-12F	
						DRAW. NO.		Tech Bes LCD-00287	
								CUST.	
EDIT	DATE	DESIG.	CHECK	APPR.	DESCRIPTION				
DESIG.			CHECK			APPR.	FUJITSU DISPLAY TECHNOLOGIES CORPORATION		30 /

**Tentative**

A

A

**③ The following troubles occur when the LCD module is not used under recommended temperature.**

- Operation under high temperature(>50°C): Display colors shift to blue.
- Storage under high temperature(>60°C): The polarizer film deteriorates and contrast decreases.
- Operation under low temperature(< 0°C): The response speed decreases considerably.
- Storage under low temperature(<-20°C): The liquid crystal may solidify and become damaged.

B

B

**④ Be sure to input the control signals at the correct timing.**

If control signals (DCLK, ENAB) are not input, or if the timing is out of the specified timing, DC voltage may be applied to the liquid crystal and, as a result, cause image sticking or deterioration of contrast.

**(5) Precautions in regards of designing module mounting**

C

C

**① Excessive force should not be applied to the screen or the rear side of the LCD module.**

Excessive pressure on the screen caused by the installation of the LCD module may deteriorate display quality and reliability. Brightness uniformity and the reliability of CCFL may decrease if the pressure is applied to the backlight module.

**② Avoid twisting and bending the LCD module.**

Excessive twist and bend may damage display quality and reliability.

**③ Avoid extending the power cable between the LCD module and inverter.**

This may cause the backlight to flicker or not to light.

**④ Keep the backlight cable apart from the metal enclosure of the LCD module.**

When frequency current for backlight driving leak to the metal enclosure, the desired brightness may not be assured.

D

D

**⑤ When mounting LCD module with M3 screws (x4), tighten the screws with torque 3.5kgf.**

**(6) Storage method**

**① Do not store the LCD module in an atmosphere of organic solvent or corrosive gas.**

In an organic solvent atmosphere, the polarizer film discolors and display quality deteriorates. In a corrosive gas environment, various parts of the module may corrode or deteriorate.

**② Store the LCD module in a FDTC package.**

At storing, FDTC packages can be stacked up to 3 boxes. The LCD module is in an anti-static bag. Keep the module in that status.

E

DOCUMENT CONTROL SECTION

DATE

						TITLE		FLC48SXC8V-12F	
						DRAW. NO.		Tech Bes LCD-00287	
								CUST.	
EDIT	DATE	DESIG.	CHECK	APPR.	DESCRIPTION				
DESIG.			CHECK			APPR.		FUJITSU DISPLAY TECHNOLOGIES CORPORATION	31 /

F



**Tentative**

③ The LCD module is recommended to be stored in humidity controlled, cool and dark locations.

Recommended storage environment

- Place : Dark (avoid direct sunlight)
- Temperature : 10~35°C
- Humidity : 50~60%RH

Note) If the module is left in an environment of 60°C and above for a long period of time, optical characteristics may deteriorate.

**(7) Disposal Method**

① LCD module

The components of this LCD module can be grouped into metal, resin, glass and so on. As the backlight contains CCFL which includes mercury, it must be disposed according to the local ordinance or regulations.

② Package

All the packages are made of recyclable papers except the anti-ESD bag.

**(8) CAUTION IN DESIGNING INVERTER**

Fluorescent lamps driven by high voltage are included in this LCD module. Please stand to the instructions below when designing inverter that lights the fluorescent lamps. Otherwise it may lead to FATAL FAILURE, such as SMOKING or FIRING.

① **APPLY PROTECTIVE CIRCUIT** in preparation for lamp breaking, wire breaking and short circuit. The protective circuit should also detect half open circuit and wire breaking in narrow gap etc.. Otherwise it may lead to fatal failure.

② **KEEP ENOUGH CURRENT CAPACITY** of inverter output for leakage current, which leaks from lamps and wire to surrounding metal material. Usually output current of about 1.5 times as same as the lamp current is necessary. But it sometimes varies due to characteristics of the inverter itself. So before determining design, please check characteristics of the inverter by connecting it to the LCD module.

③ **KEEP ENOUGH TEMPERATURE MARGIN** for each parts mounted on inverter. Temperature of the parts becomes higher when they are mounted in the final products due to heating inside. The temperature of each parts **MUST NOT** increase over the guaranteed temperature.

DATE DOCUMENT CONTROL SECTION

						TITLE		FLC48SXC8V-12F	
						DRAW. NO.		Tech Bes LCD-00287	
								CUST.	
EDIT	DATE	DESIG.	CHECK	APPR.	DESCRIPTION				
DESIG.			CHECK			APPR.	FUJITSU DISPLAY TECHNOLOGIES CORPORATION		32 /

**(8) Return method of the LCD module requested for repair or analysis of the problem**

- When returning the LCD modules, adhere to the following procedures not to damage the LCD panel or the backlight cables. (Fig. 17-1(a)~(b))  
When the LCD module is returned without following the specified packaging procedures, FDTC will not take responsibility for the damages caused by the failure of the packaging method.
- Please be cautious not to put fingerprints or other stains on the display by wearing a glove or fingerstall when managing LCD module modules, including faulty modules that require to be returned .

(1) Attach protective sheet.

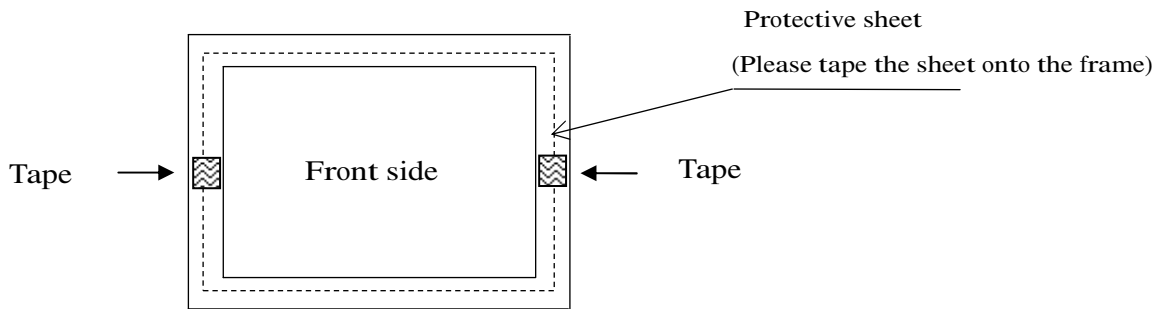

(2) Put the backlight cables in slots.

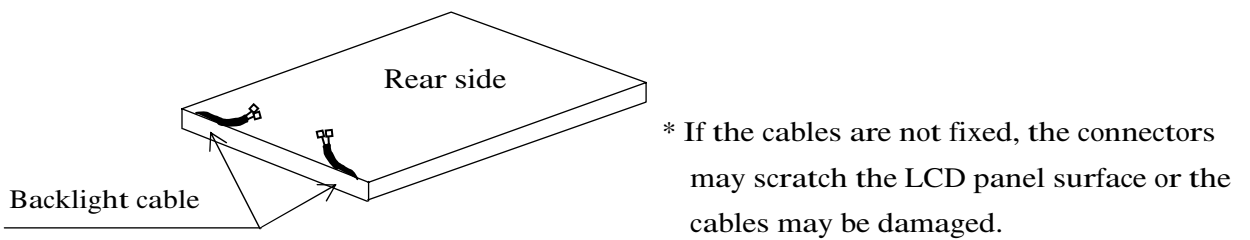

(3) Put the LCD module into the anti-electrostatic bag  
(Please do not use torn anti-electrostatic bags)

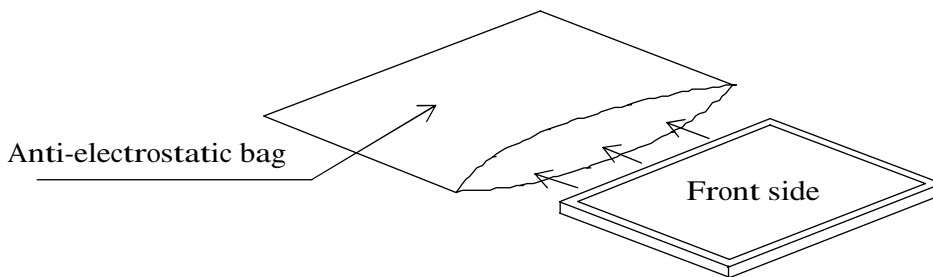

Fig. 17-1(a) Packaging method

DOCUMENT CONTROL SECTION
DATE

						TITLE		FLC48SXC8V-12F	
						DRAW. NO.			CUST.
						Tech Bes LCD-00287			
EDIT	DATE	DESIG.	CHECK	APPR.	DESCRIPTION				FUJITSU DISPLAY TECHNOLOGIES CORPORATION
DESIG.			CHECK			APPR.		33 /	



Tentative

A

B

C

D

A

B

C

D

E

F

⑤

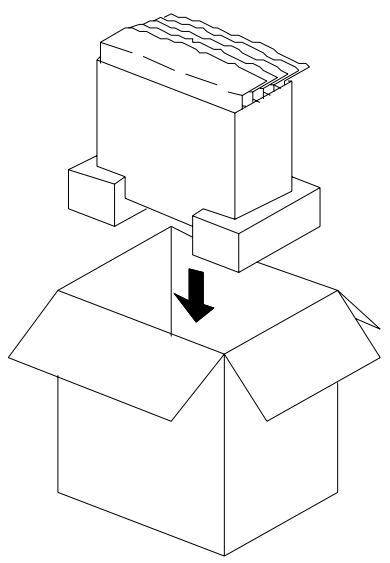

⑥

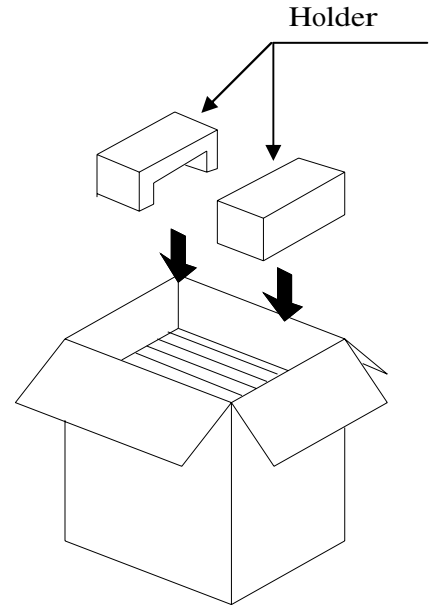

The Front side of LCD units should be faced to the direction of the making on carton box.

⑦

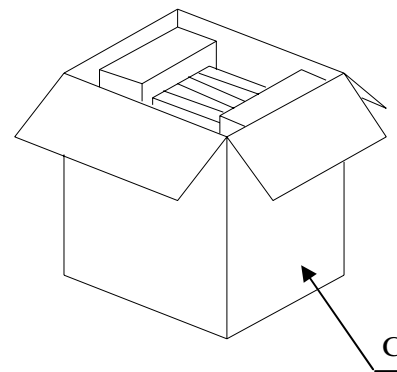

Carton Box

⑧

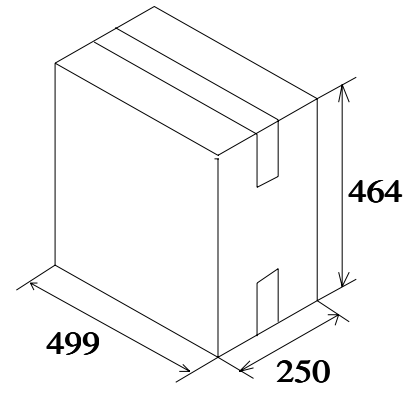

\*\*The arrowheads are shown on the holders.\*\*

Fig. 17-1(b) Packaging method

- When not using the carton box manufactured by FDTC  
Please pack the LCD modules one by one and make sure not to damage the LCD modules when transporting.

DOCUMENT CONTROL SECTION

DATE

						TITLE		FLC48SXC8V-12F	
						DRAW. NO.		Tech Bes LCD-00287	
								CUST.	
EDIT	DATE	DESIG.	CHECK	APPR.	DESCRIPTION		FUJITSU DISPLAY TECHNOLOGIES CORPORATION		35 /
	DESIG.			CHECK		APPR.			

**Tentative**

**(9) Others**

**① If the LCD panel is damaged, do not inhale and do not swallow the liquid crystal.**  
 If the liquid crystal adhere to the body or cloths, wash it off with soap immediately.  
 Follow regular precautions for electronic components.

**② Flux residue on the printed circuit board is harmless to the quality and reliability of LCD module.**  
 FDTC has adopted non-wash technology on module assembly process.

**18. PRECAUTIONS FOR USE**

This Product is designed, developed and manufactured as contemplated for general use, including without limitation, general office use, personal use, household use, and ordinary industrial use, but is not designed, developed and manufactured as contemplated for use accompanying fatal risks or dangers that, unless extremely high safety is secured, could lead directly to death, personal injury, severe physical damage or other loss (hereinafter "High Safety Required Use"), including without limitation, nuclear reaction control in nuclear facility, aircraft flight control, air traffic control, mass transport control, medical life support system, missile launch control in weapon system. If customer's product possibly falls under the category of High Safety Required Use, please consult with our sales representatives in charge before such use. In addition, FDTC shall not be liable against the Customer and/or any third party for any claims or damages arising in connection with the High Safety Required Use of the Product without permission.

**19. MISCELLANEOUS**

Specifications of the TFT-LCD panel and other components used in the LCD module are subject to change. Both parties shall discuss together before change.  
 If any doubt is raised in the content of the specifications, both parties shall discuss and make best effort for the agreement.

DATE DOCUMENT CONTROL SECTION

						TITLE		FLC48SXC8V-12F	
						DRAW. NO.			CUST.
						Tech Bes LCD-00287			
EDIT	DATE	DESIG.	CHECK	APPR.	DESCRIPTION		FUJITSU DISPLAY TECHNOLOGIES CORPORATION		36 /
	DESIG.		CHECK	APPR.					

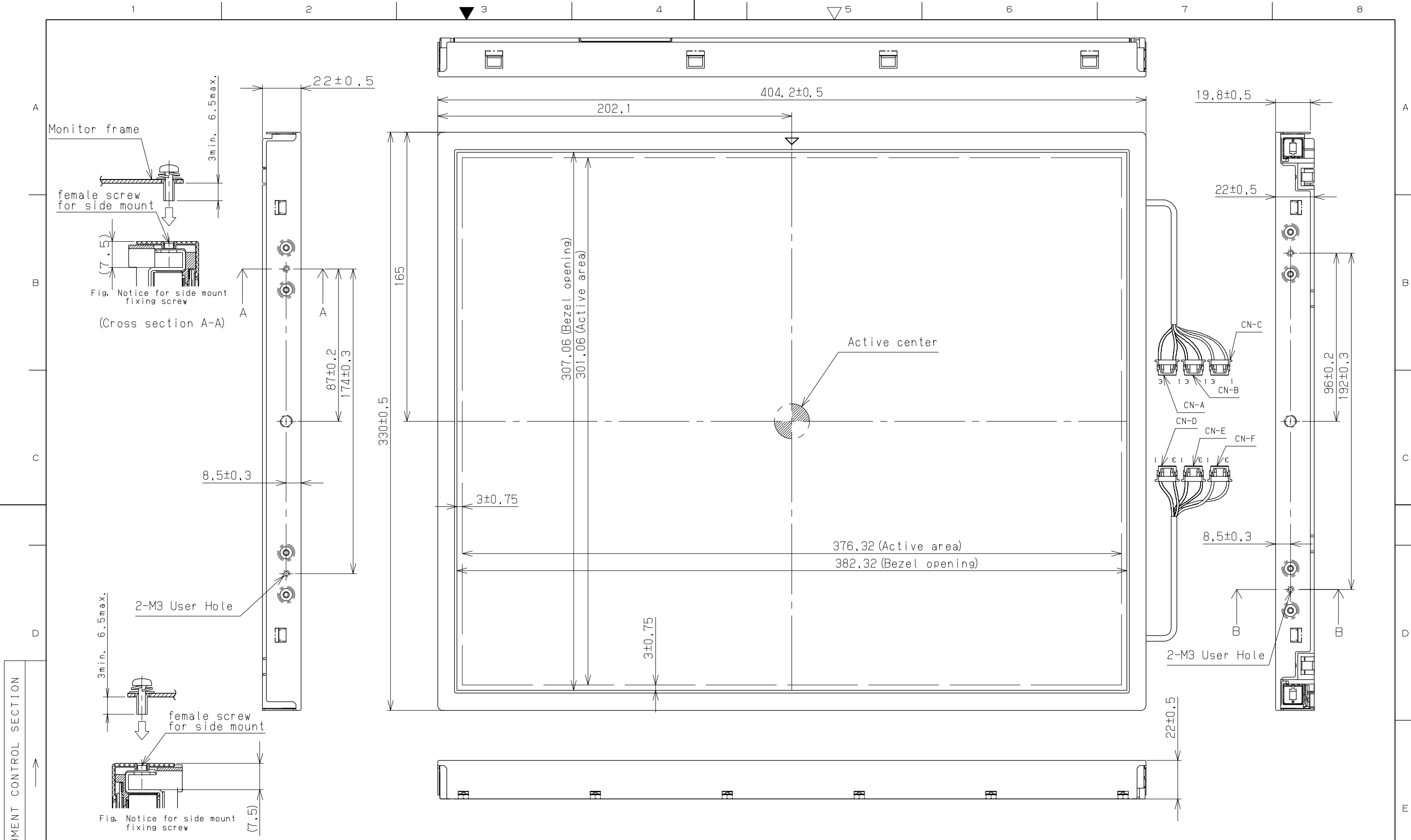

Figure 20-1 Module outline dimension (front)

DATE DOCUMENT CONTROL SECTION

TENTATIVE

							TITLE FLC48SXC8V-12F	
							DRAW. NO.	CUST.
							Tech Bes LCD-00287	
EDIT.	DATE	DESIG.	CHECK	DESCRIPTION			FUJITSU DISPLAY TECHNOLOGIES CORPORATION	SHEET 37/
DESIG.			CHECK		APPR.			

1 2 3 4 5 6 7 8

A B C D E

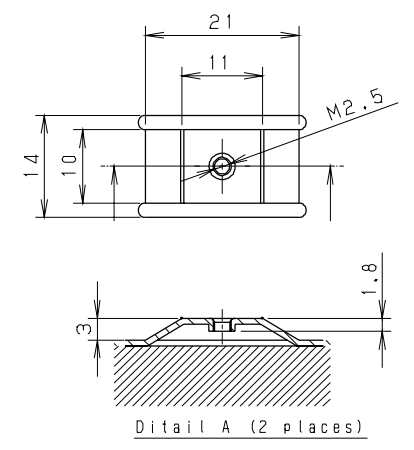
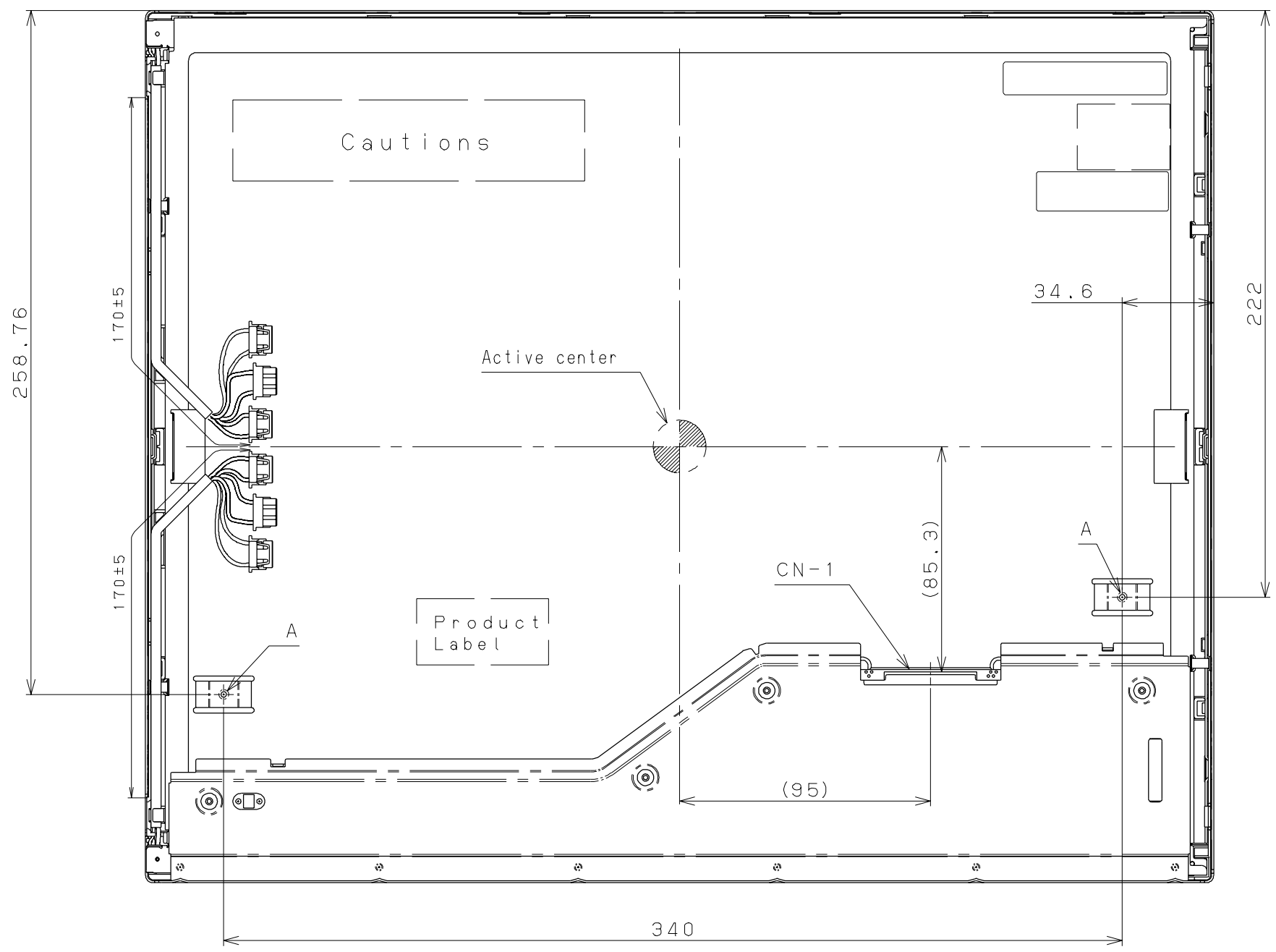

Figure 20-2 Module outline dimension (Rear)

TENTATIVE

NOTE  
1) Unspecified tolerance to be ±0.5

						TITLE FLC48SXC8V-12F	
						DRAW. NO. Tech Bes LCD-00287	
						CUST.	
EDIT.	DATE	DESIG.	CHECK	DESCRIPTION		FUJITSU DISPLAY TECHNOLOGIES CORPORATION	
DESIG.			CHECK	APPR.		38/38	

DATE DOCUMENT CONTROL SECTION

1 2 3 4 5 6 7 8 93.04 FDNC-3901-3