

# SPECIFICATION FOR APPROVAL

( ) Preliminary Specification

(◆) Final Specification

Title	19.0" SXGA TFT LCD
-------	--------------------

BUYER	
MODEL	

SUPPLIER	LG.Philips LCD CO., Ltd.
*MODEL	LM190E01
SUFFIX	C4

\*When you obtain standard approval,  
please use the above model name without suffix

SIGNATURE	DATE
/	_____
/	_____
/	_____

Please return 1 copy for your confirmation with your signature and comments.

APPROVED BY	DATE
G T. Kim / G.Manager	_____
<b>REVIEWED BY</b>	
K.J. Kwon / Manager	_____
<b>PREPARED BY</b>	
K N. Kim / Engineer	_____

**Product Engineering Dept.  
LG. Philips LCD Co., Ltd**

Product Specification

Contents

No	ITEM	Page
	COVER	1
	CONTENTS	2
	RECORD OF REVISIONS	3
<b>1</b>	GENERAL DESCRIPTION	4
<b>2</b>	ABSOLUTE MAXIMUM RATINGS	5
<b>3</b>	ELECTRICAL SPECIFICATIONS	6
3-1	ELECTRICAL CHARACTREISTICS	6
3-2	INTERFACE CONNECTIONS	9
3-3	SIGNAL TIMING SPECIFICATIONS	12
3-4	SIGNAL TIMING WAVEFORMS	13
3-5	COLOR INPUT DATA REFERNECE	14
3-6	POWER SEQUENCE	15
<b>4</b>	OPTICAL SFECIFICATIONS	16
<b>5</b>	MECHANICAL CHARACTERISTICS	20
<b>6</b>	RELIABILITY	23
<b>7</b>	INTERNATIONAL STANDARDS	24
7-1	SAFETY	24
7-2	EMC	24
<b>8</b>	PACKING	25
8-1	DESIGNATION OF LOT MARK	25
8-2	PACKING FORM	25
<b>9</b>	PRECAUTIONS	26



## Product Specification

## 1. General Description

LM190E01-C4 is a Color Active Matrix Liquid Crystal Display with an integral Cold Cathode Fluorescent Lamp(CCFL) backlight system. The matrix employs a-Si Thin Film Transistor as the active element. It is a transmissive type display operating in the normally black mode. It has a 19.0 inch diagonally measured active display area with SXGA resolution (1024 vertical by 1280 horizontal pixel array) Each pixel is divided into Red, Green and Blue sub-pixels or dots which are arranged in vertical stripes. Gray scale or the brightness of the sub-pixel color is determined with a 8-bit gray scale signal for each dot, thus, a palette of more than 16,777,216 colors. It has been designed to apply the 8Bit parallel CMOS interface. It is intended to support applications where thin thickness, wide viewing angle, low power are critical factors and graphic displays are important. In combination with the vertical arrangement of the sub-pixels, the LM190E01-C4 characteristics provide an excellent flat panel display for office automation products such as monitors.

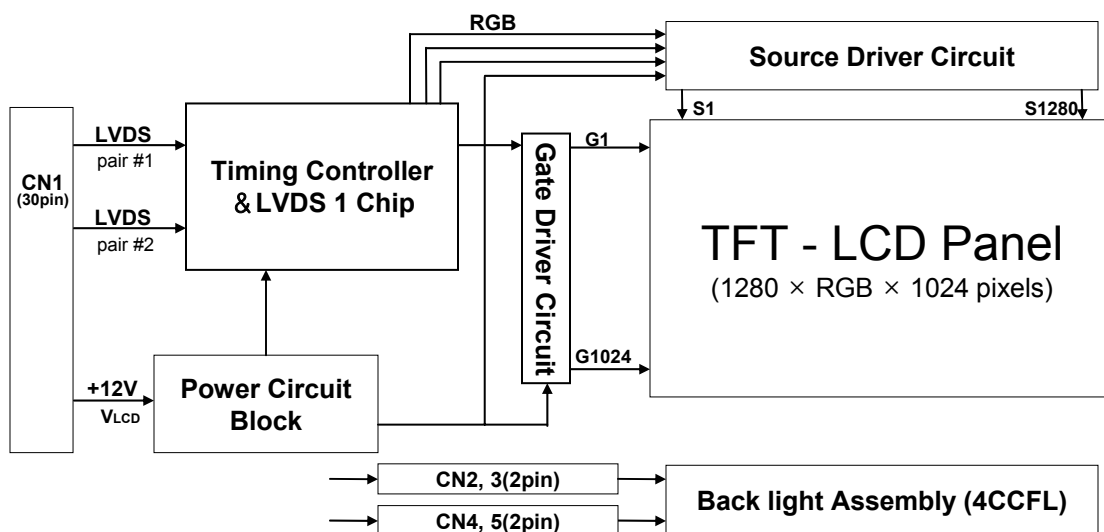

### General Features

Active screen size	19.0 inches (481.84mm) diagonal
Outline Dimension	404.2(H) x 330.0(V) x 22.3(D) mm(Typ.)
Pixel Pitch	0.294 mm x 0.294 mm
Pixel Format	1280 horizontal By 1024 vertical Pixels. RGB stripe arrangement
Interface	LVDS 2Port
Color depth	8-bit, 16,777,216 color
Luminance, white	250 cd/m <sup>2</sup> ( Center 1Point, typ)
Viewing Angle (CR>10)	Viewing Angle Free [ R/L 176(Typ.), U/D 176(Typ.) ]
Power Consumption	Total 22.94 Watt(Typ.), (3.29 Watt @V <sub>LCD</sub> , 19.65 @[Lamp=7.5mA])
Weight	2,800g (Typ.)
Display operating mode	Transmissive mode, normally Black
Surface treatments	Hard coating (3H), Anti-glare treatment of the front polarizer

Product Specification

## 2. Absolute Maximum Ratings

The following are maximum values which, if exceeded, may cause faulty operation or damage to the unit.

Table 1. Absolute Maximum Ratings

Parameter	Symbol	Values		Units	Notes
		Min	Max		
Power Supply Input Voltage	$V_{LCD}$	-0.3	+14.0	Vdc	At 25°C
Operating Temperature	$T_{OP}$	0	50	°C	1
Storage Temperature	$T_{ST}$	-20	60	°C	
Operating Ambient Humidity	$H_{OP}$	10	90	%RH	
Storage Humidity	$H_{ST}$	10	90	%RH	

Note : 1. Temperature and relative humidity range are shown in the figure below.  
Wet bulb temperature should be 39 °C Max, and no condensation of water.

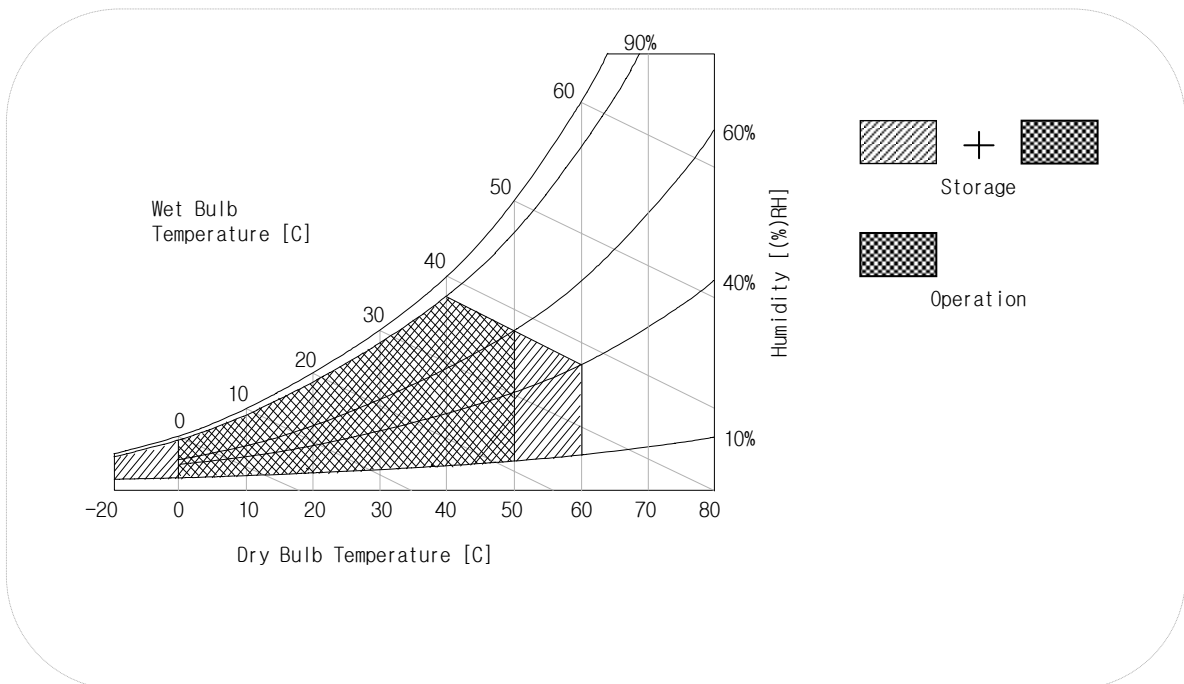

Product Specification

### 3. Electrical Specifications

#### 3-1. Electrical Characteristics

It requires two power inputs. One is employed to power the LCD electronics and to drive the TFT array and liquid crystal. The second input power for the CCFL/Backlight, is typically generated by an inverter. The inverter is an external unit to the LCDs.

Table 2\_1. ELECTRICAL CHARACTERISTICS

Parameter	Symbol	Values			Unit	Notes
		Min	Typ	Max		
MODULE :						
Power Supply Input Voltage	$V_{LCD}$	11.4	12.0	12.6	Vdc	
Power Supply Input Current	$I_{LCD}$	-	274	315	mA	1
		-	360	468	mA	2
Power Consumption	$P_{LCD}$	-	3.29	3.78	Watt	1
Inrush current	$I_{RUSH}$	-	-	3.0	A	3

Note :

1. The specified current and power consumption are under the  $V_{LCD}=12.0V$ ,  $25 \pm 2^{\circ}C$ ,  $f_v=60Hz$  condition whereas mosaic pattern(8 x 6) is displayed and  $f_v$  is the frame frequency.
2. The current is specified at the maximum current pattern below
3. The duration of rush current is about 2ms and rising time of power Input is 1ms(min.).

White : 255Gray  
Black : 0Gray

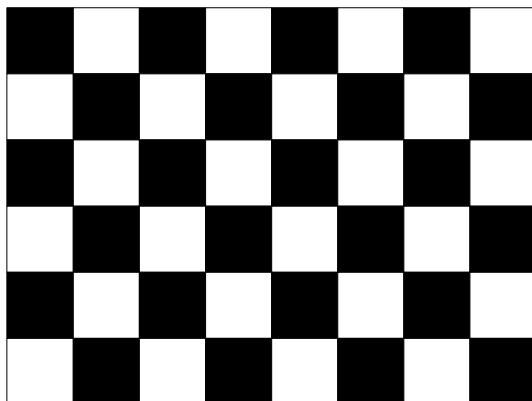

Mosaic Pattern(8 x 6)

Maximum current pattern

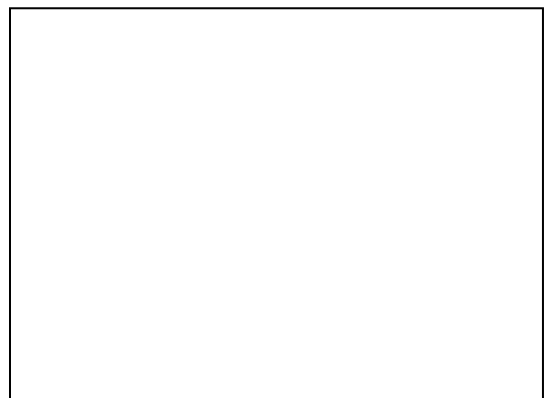

white pattern

## Product Specification

**Table 2\_2. ELECTRICAL CHARACTERISTICS**

Parameter	Symbol	Values			Unit	Notes
		Min	Typ	Max		
<b>LAMP :</b>						
Operating Voltage	$V_{BL}$	645(8.0mA)	655(7.5mA)	790(3mA)	$V_{RMS}$	1, 2
Operating Current	$I_{BL}$	3.0	7.5	8.0	$mA_{RMS}$	1
Established Starting Voltage	$V_s$					1, 3
	at 25 °C			1,100	$V_{RMS}$	
	at 0 °C			1,400	$V_{RMS}$	
Operating Frequency	$f_{BL}$	40	60	70	kHz	4
Discharge Stabilization Time	$T_s$			3	Min	1, 5
Power Consumption	$P_{BL}$		19.65	21.62	Watt	6
Life Time		40,000			Hrs	1, 7

Note : The design of the inverter must have specifications for the lamp in LCD Assembly.

The performance of the Lamp in LCM, for example life time or brightness, is extremely influenced by the characteristics of the DC-AC inverter. So all the parameters of an inverter should be carefully designed so as not to produce too much leakage current from high-voltage output of the inverter.

When you design or order the inverter, please make sure unwanted lighting caused by the mismatch of the lamp and the inverter (no lighting, flicker, etc) never occurs. When you confirm it, the LCD-Assembly should be operated in the same condition as installed in you instrument.

※ Do not attach a conducting tape to lamp connecting wire.

If the lamp wire attach to a conducting tape, TFT-LCD Module has a low luminance and the inverter has abnormal action. Because leakage current is occurred between lamp wire and conducting tape.

- Specified values are for a single lamp.
- Operating voltage is measured at  $25 \pm 2^\circ\text{C}$ . The variance of the voltage is  $\pm 10\%$ .
- The voltage above  $V_s$  should be applied to the lamps for more than 1 second for start-up.  
(Inverter open voltage must be more than lamp starting voltage.)  
Otherwise, the lamps may not be turned on. The used lamp current is the lamp typical current.
- Lamp frequency may produce interface with horizontal synchronous frequency and as a result this may cause beat on the display. Therefore lamp frequency shall be as away possible from the horizontal synchronous frequency and from its harmonics in order to prevent interference.
- Let's define the brightness of the lamp after being lighted for 5 minutes as 100%.  
 $T_s$  is the time required for the brightness of the center of the lamp to be not less than 95%.
- The lamp power consumption shown above does not include loss of external inverter.  
The used lamp current is the lamp typical current. ( $P_{BL} = V_{BL} \times I_{BL} \times N_{Lamp}$ )
- The life is determined as the time at which brightness of the lamp is 50% compared to that of initial value at the typical lamp current on condition of continuous operating at  $25 \pm 2^\circ\text{C}$ .

Product Specification

8. The output of the inverter must have symmetrical(negative and positive) voltage waveform and symmetrical current waveform (Unsymmetrical ratio is less than 10%). Please do not use the inverter which has unsymmetrical voltage and unsymmetrical current and spike wave. Requirements for a system inverter design, which is intended to have a better display performance, a better power efficiency and a more reliable lamp, are following.

It shall help increase the lamp lifetime and reduce leakage current.

- a. The asymmetry rate of the inverter waveform should be less than 10%.
- b. The distortion rate of the waveform should be within  $\sqrt{2} \pm 10\%$ .

\* Inverter output waveform had better be more similar to ideal sine wave.

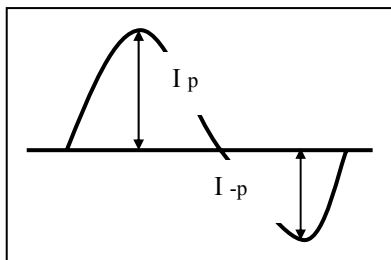

\* Asymmetry rate:

$$| I_p - I_{-p} | / I_{rms} \times 100\%$$

\* Distortion rate

$$I_p \text{ (or } I_{-p}) / I_{rms}$$

- 9. The inverter which is combined with this LCM, is highly recommended to connect coupling(ballast) condenser at the high voltage output side. When you use the inverter which has not coupling(ballast) condenser, it may cause abnormal lamp lighting because of biased mercury as time goes.
- 10. In case of edgy type back light with over 4 parallel lamps, input current and voltage wave form should be synchronized



### 3-2. Interface Connections

- LCD Connector(CN1) : GT101-30S-H16 (Manufactured by LGC) or Equivalent
- Mating Connector : FI-X30H (Manufactured by JAE) or Equivalent

**Table 3. MODULE CONNECTOR(CN1) PIN CONFIGURATION**

Pin No	Symbol	Description
1	FR0M	Minus signal of odd channel 0 (LVDS)
2	FR0P	Plus signal of odd channel 0 (LVDS)
3	FR1M	Minus signal of odd channel 1 (LVDS)
4	FR1P	Plus signal of odd channel 1 (LVDS)
5	FR2M	Minus signal of odd channel 2 (LVDS)
6	FR2P	Plus signal of odd channel 2 (LVDS)
7	GND	Ground
8	FCLKINM	Minus signal of odd clock channel (LVDS)
9	FCLKINP	Plus signal of odd clock channel (LVDS)
10	FR3M	Minus signal of odd channel 3 (LVDS)
11	FR3P	Plus signal of odd channel 3 (LVDS)
12	SR0M	Minus signal of even channel 0 (LVDS)
13	SR0P	Plus signal of even channel 0 (LVDS)
14	GND	Ground
15	SR1M	Minus signal of even channel 1 (LVDS)
16	SR1P	Plus signal of even channel 1 (LVDS)
17	GND	Ground
18	SR2M	Minus signal of even channel 2 (LVDS)
19	SR2P	Plus signal of even channel 2 (LVDS)
20	SCLKINM	Minus signal of even clock channel (LVDS)
21	SCLKINP	Plus signal of even clock channel (LVDS)
22	SR3M	Minus signal of even channel 3 (LVDS)
23	SR3P	Plus signal of even channel 3 (LVDS)
24	GND	Ground
25	NC	No Connection
26	NC	No Connection
27	NC	No Connection
28	V <sub>LCD</sub>	Power Supply +12.0V
29	V <sub>LCD</sub>	Power Supply +12.0V
30	V <sub>LCD</sub>	Power Supply +12.0V

**Rear view of LCM**

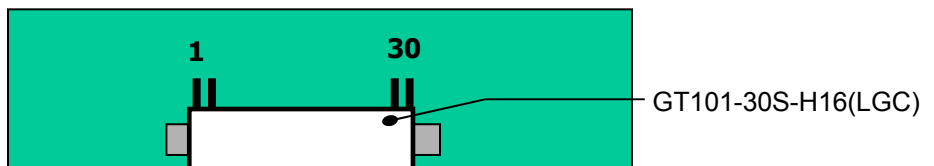

Note: 1. NC: No Connection.

- All GND(ground) pins should be connected together and to V<sub>SS</sub> which should also be connected to the LCD's metal frame.
- All V<sub>LCD</sub> (power input) pins should be connected together.
- Input Level of LVDS signal is based on the IEA 664 Standard.

## Product Specification

**Table 4. REQUIRED SIGNAL ASSIGNMENT FOR Flat Link(TI:SN75LVDS83) Transmitter**

Pin #	Pin Name	Require Signal	Pin #	Pin Name	Require Signal
1	Vcc	Power Supply for TTL Input	29	GND	Ground pin for TTL
2	D5	TTL Input (R7)	30	D26	TTL Input (DE)
3	D6	TTL Input (R5)	31	T <sub>X</sub> CLKIN	TTL Level clock Input
4	D7	TTL Input (G0)	32	PWR DWN	Power Down Input
5	GND	Ground pin for TTL	33	PLL GND	Ground pin for PLL
6	D8	TTL Input (G1)	34	PLL Vcc	Power Supply for PLL
7	D9	TTL Input (G2)	35	PLL GND	Ground pin for PLL
8	D10	TTL Input (G6)	36	LVDS GND	Ground pin for LVDS
9	Vcc	Power Supply for TTL Input	37	T <sub>X</sub> OUT3 +	Positive LVDS differential data output 3
10	D11	TTL Input (G7)	38	T <sub>X</sub> OUT3 –	Negative LVDS differential data output 3
11	D12	TTL Input (G3)	39	T <sub>X</sub> CLKOUT +	Positive LVDS differential clock output
12	D13	TTL Input (G4)	40	T <sub>X</sub> CLKOUT –	Negative LVDS differential clock output
13	GND	Ground pin for TTL	41	T <sub>X</sub> OUT2 +	Positive LVDS differential data output 2
14	D14	TTL Input (G5)	42	T <sub>X</sub> OUT2 –	Negative LVDS differential data output 2
15	D15	TTL Input (B0)	43	LVDS GND	Ground pin for LVDS
16	D16	TTL Input (B6)	44	LVDS Vcc	Power Supply for LVDS
17	Vcc	Power Supply for TTL Input	45	T <sub>X</sub> OUT1 +	Positive LVDS differential data output 1
18	D17	TTL Input (B7)	46	T <sub>X</sub> OUT1 –	Negative LVDS differential data output 1
19	D18	TTL Input (B1)	47	T <sub>X</sub> OUT0 +	Positive LVDS differential data output 0
20	D19	TTL Input (B2)	48	T <sub>X</sub> OUT0 –	Negative LVDS differential data output 0
21	GND	Ground pin for TTL Input	49	LVDS GND	Ground pin for LVDS
22	D20	TTL Input (B3)	50	D27	TTL Input (R6)
23	D21	TTL Input (B4)	51	D0	TTL Input (R0)
24	D22	TTL Input (B5)	52	D1	TTL Input (R1)
25	D23	TTL Input (RSVD)	53	GND	Ground pin for TTL
26	Vcc	Power Supply for TTL Input	54	D2	TTL Input (R2)
27	D24	TTL Input (HSYNC)	55	D3	TTL Input (R3)
28	D25	TTL Input (VSYNC)	56	D4	TTL Input (R4)

Notes : Refer to LVDS Transmitter Data Sheet for detail descriptions.

## Product Specification

**Table 5. BACKLIGHT CONNECTOR PIN CONFIGURATION(CN2,CN3,CN4,CN5)**

The backlight interface connector is a model 1674817-1(CN2/CN3/CN4/CN5) manufactured by AMP. The mating connector part number are SM02B-BHSS-1-TB(2pin) or equivalent. The pin configuration for the connector is shown in the table below.

No	Pin	Symbol	Description	Notes
CN2	1	HV	Power supply for lamp 1(High voltage side) - Gray	1
	2	LV	Power supply for lamp 1(Low voltage side) - Black	2
CN3	1	HV	Power supply for lamp 2(High voltage side) - Sky Blue	1
	2	LV	Power supply for lamp 2(Low voltage side) - Blue	2
CN4	1	HV	Power supply for lamp 3(High voltage side) - Gray	1
	2	LV	Power supply for lamp 3(Low voltage side) - Black	2
CN5	1	HV	Power supply for lamp 4(High voltage side) - Sky Blue	1
	2	LV	Power supply for lamp 4(Low voltage side) - Blue	2

Notes: 1. The high voltage power terminal is colored gray, sky blue.  
 2. The low voltage pin color is black, blue.

## &lt;BACKLIGHT CONNECTOR DIAGRAM&gt;



## Product Specification

### 3-3. Signal Timing Specifications

This is the signal timing required at the input of the User connector. All of the interface signal timing should be satisfied with the following specifications for it's proper operation.

**Table 6. Timing Table**

ITEM	Symbol		Min	Typ	Max	Unit	Note
DCLK	Period	$t_{CLK}$	23.65	18.52	14.82	ns	
	Frequency	-	42.3	54.0	67.5	MHz	
Hsync	Period	$t_{HP}$	664	844	1024	$t_{CLK}$	
	Frequency	$f_H$	50.10	63.98	79.95	KHz	
	Width	$t_{WH}$	8	56	-	$t_{CLK}$	
Vsync	Period	$t_{VP}$	1034	1066	1098	$t_{HP}$	
	Frequency	$f_V$	47	60	75	Hz	
	Width	$t_{WV}$	2	3	-	$t_{HP}$	
DE (Data Enable)	Horizontal Valid	$t_{HV}$	640	640	640	$t_{CLK}$	
	Horizontal Back Porch	$t_{HBP}$	8	124	-		
	Horizontal Front Porch	$t_{HFP}$	8	24	-		
	Horizontal Blank	-	24	-	$t_{HP} - t_{HV}$		
	Vertical Valid	$t_{VV}$	1024	1024	1024	$t_{HP}$	
	Vertical Back Porch	$t_{VBP}$	1	38	-		
	Vertical Front Porch	$t_{VFP}$	1	1	-		
Vertical Blank	-	10	-	$t_{VP} - t_{VV}$			

**Note:**

Hsync period and Hsync width-active should be even number times of  $t_{CLK}$ .

If the value is odd number times of  $t_{CLK}$ , display control signal can be asynchronous.

In order to operate this LCM a Hsync, Vsync and DE (Data Enable) signals should be used.

1. The performance of the electro-optical characteristics may be influenced by variance of the vertical refresh rates.
2. Vsync, Hsync should be keep the above specification.
3. Hsync Period, Hsync Width and Horizontal Back Porch should be any times of a character number (8).

### 3-4. Signal Timing Waveforms

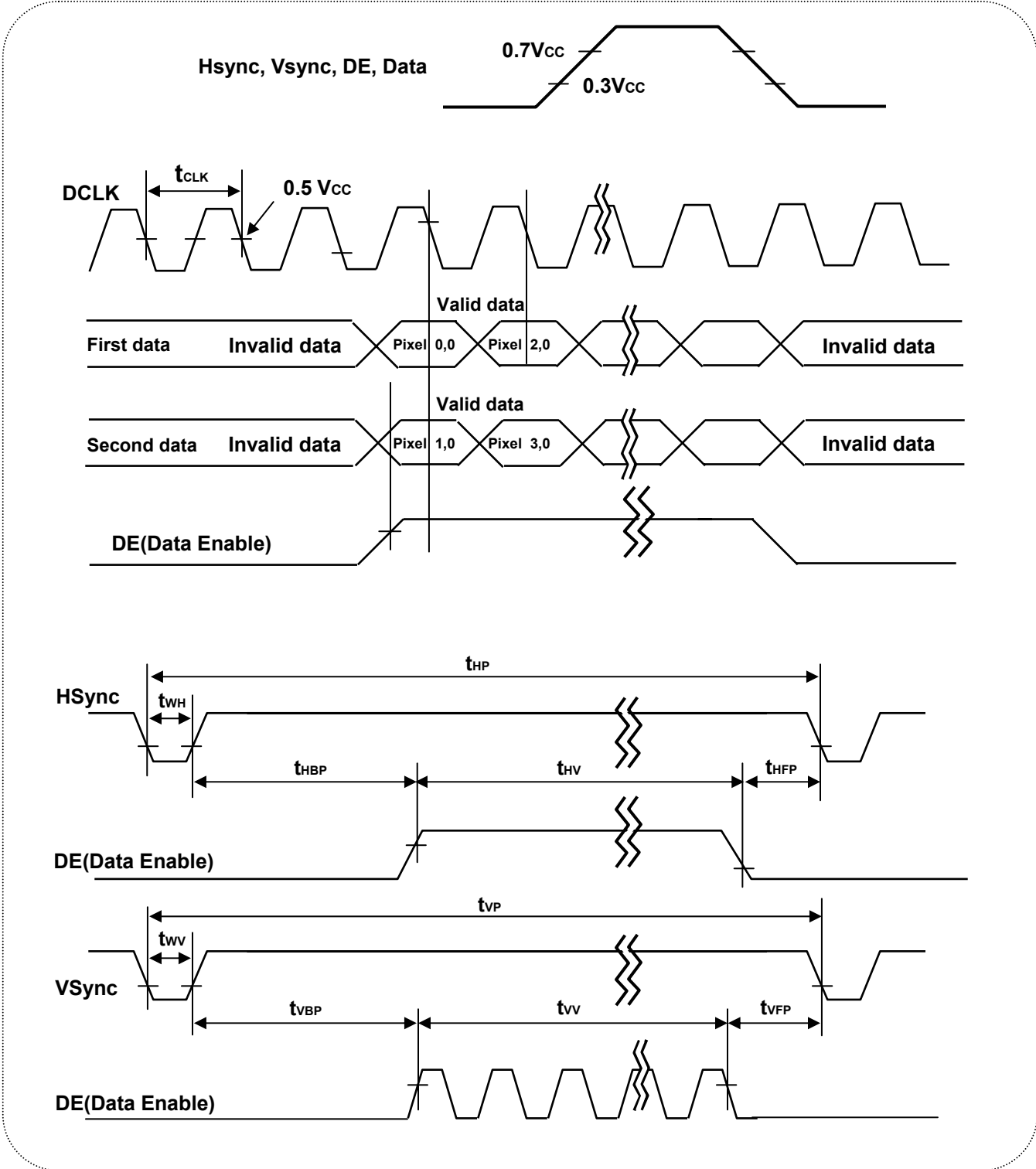

## Product Specification

**3-5. Color Input Data Reference**

The brightness of each primary color (red, green and blue) is based on the 8-bit gray scale data input for the color ; the higher the binary input, the brighter the color. The table below provides a reference for color versus data input.

Table 9. COLOR DATA REFERENCE

Color		Input Color Data																							
		Red								Green								Blue							
		MSB				LSB				MSB				LSB				MSB				LSB			
		R7	R6	R5	R4	R3	R2	R1	R0	G7	G6	G5	G4	G3	G2	G1	G0	B7	B6	B5	B4	B3	B2	B1	B0
Basic Color	Black	0	0	0	0	0	0	0	0	0	0	0	0	0	0	0	0	0	0	0	0	0	0	0	0
	Red (255)	1	1	1	1	1	1	1	1	0	0	0	0	0	0	0	0	0	0	0	0	0	0	0	0
	Green (255)	0	0	0	0	0	0	0	0	1	1	1	1	1	1	1	1	0	0	0	0	0	0	0	0
	Blue (255)	0	0	0	0	0	0	0	0	0	0	0	0	0	0	0	0	1	1	1	1	1	1	1	1
	Cyan	0	0	0	0	0	0	0	0	1	1	1	1	1	1	1	1	1	1	1	1	1	1	1	1
	Magenta	1	1	1	1	1	1	1	1	0	0	0	0	0	0	0	0	1	1	1	1	1	1	1	1
	Yellow	1	1	1	1	1	1	1	1	1	1	1	1	1	1	1	1	0	0	0	0	0	0	0	0
	White	1	1	1	1	1	1	1	1	1	1	1	1	1	1	1	1	1	1	1	1	1	1	1	1
Red	Red(000) Dark	0	0	0	0	0	0	0	0	0	0	0	0	0	0	0	0	0	0	0	0	0	0	0	0
	Red(001)	0	0	0	0	0	0	0	1	0	0	0	0	0	0	0	0	0	0	0	0	0	0	0	0
	Red(002)	0	0	0	0	0	0	1	0	0	0	0	0	0	0	0	0	0	0	0	0	0	0	0	0
	-----	-	-	-	-	-	-	-	-	-	-	-	-	-	-	-	-	-	-	-	-	-	-	-	-
	-----	-	-	-	-	-	-	-	-	-	-	-	-	-	-	-	-	-	-	-	-	-	-	-	-
	Red(253)	1	1	1	1	1	1	0	1	0	0	0	0	0	0	0	0	0	0	0	0	0	0	0	0
	Red(254)	1	1	1	1	1	1	1	0	0	0	0	0	0	0	0	0	0	0	0	0	0	0	0	0
Red(255) Bright	1	1	1	1	1	1	1	1	0	0	0	0	0	0	0	0	0	0	0	0	0	0	0	0	
Green	Green(000) Dark	0	0	0	0	0	0	0	0	0	0	0	0	0	0	0	0	0	0	0	0	0	0	0	0
	Green(001)	0	0	0	0	0	0	0	0	0	0	0	0	0	0	1	0	0	0	0	0	0	0	0	0
	Green(002)	0	0	0	0	0	0	0	0	0	0	0	0	0	0	1	0	0	0	0	0	0	0	0	0
	-----	-	-	-	-	-	-	-	-	-	-	-	-	-	-	-	-	-	-	-	-	-	-	-	-
	-----	-	-	-	-	-	-	-	-	-	-	-	-	-	-	-	-	-	-	-	-	-	-	-	-
	Green(253)	0	0	0	0	0	0	0	0	1	1	1	1	1	1	0	1	0	0	0	0	0	0	0	0
	Green(254)	0	0	0	0	0	0	0	0	1	1	1	1	1	1	1	0	0	0	0	0	0	0	0	0
Green(255) Bright	0	0	0	0	0	0	0	0	1	1	1	1	1	1	1	1	0	0	0	0	0	0	0	0	
Blue	Blue(000) Dark	0	0	0	0	0	0	0	0	0	0	0	0	0	0	0	0	0	0	0	0	0	0	0	0
	Blue(001)	0	0	0	0	0	0	0	0	0	0	0	0	0	0	0	0	0	0	0	0	0	0	0	1
	Blue(002)	0	0	0	0	0	0	0	0	0	0	0	0	0	0	0	0	0	0	0	0	0	0	1	0
	-----	-	-	-	-	-	-	-	-	-	-	-	-	-	-	-	-	-	-	-	-	-	-	-	-
	-----	-	-	-	-	-	-	-	-	-	-	-	-	-	-	-	-	-	-	-	-	-	-	-	-
	Blue(253)	0	0	0	0	0	0	0	0	0	0	0	0	0	0	0	0	1	1	1	1	1	1	0	1
	Blue(254)	0	0	0	0	0	0	0	0	0	0	0	0	0	0	0	0	1	1	1	1	1	1	1	0
Blue(255) Bright	0	0	0	0	0	0	0	0	0	0	0	0	0	0	0	0	1	1	1	1	1	1	1	1	

Product Specification

**3-6. Power Sequence**

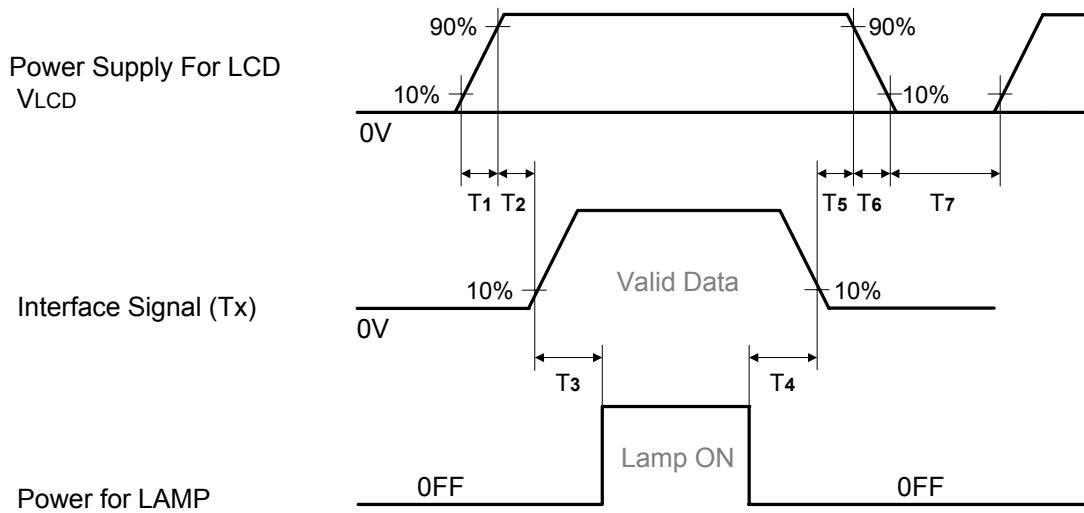

**Table 8. POWER SEQUENCE**

Parameter	Values			Units
	Min	Typ	Max	
T1	1	-	10	ms
T2	0.5	-	50	ms
T3	200	-	-	ms
T4	200	-	-	ms
T5	0.5	-	50	ms
T6	-	-	100	ms
T7	1	-	-	ms

- Notes :
1. Please avoid floating state of interface signal at invalid period.
  2. When the interface signal is invalid, be sure to pull down the power supply for LCD  $V_{LCD}$  to 0V.
  3. Lamp power must be turn on after power supply for LCD an interface signal are valid.

Product Specification

4. Optical Specification

Optical characteristics are determined after the unit has been 'ON' for 30 minutes in a dark environment at 25°C. The values specified are at an approximate distance 50cm from the LCD surface at a viewing angle of  $\phi$  and  $\theta$  equal to 0°.

FIG. 1 presents additional information concerning the measurement equipment and method.

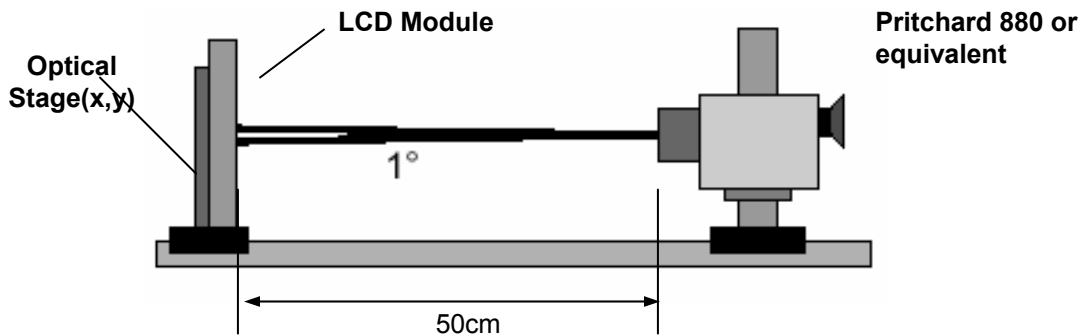

FIG. 1 Optical Characteristic Measurement Equipment and Method

Table 9. OPTICAL CHARACTERISTICS

Ta= 25°C, V<sub>LCD</sub>=12.0V, fv=60HzDclk=54MHz, I<sub>BL</sub>=7.5mA

Parameter	Symbol	Values			Units	Notes	
		Min	Typ	Max			
Contrast Ratio	CR	250	400	-		1	
Surface Luminance, white	L <sub>WH</sub>	200	250	-	cd/m <sup>2</sup>	2	
Luminance Variation	$\delta_{\text{WHITE}}$ 5P			1.25		3	
Response Time	Rise Time	Tr <sub>R</sub>	12	20	ms	4	
	Decay Time	Tr <sub>D</sub>	13	20	ms		
Color Coordinates [CIE1931]	RED	Rx	Typ -0.03	0.640	Typ +0.03		
		Ry		0.344			
	GREEN	Gx		0.299			
		Gy		0.602			
	BLUE	Bx		0.145			
		By		0.074			
	WHITE	Wx		0.313			
		Wy		0.329			
Viewing Angle (CR>10)							
	x axis, right( $\phi=0^\circ$ )	$\theta_r$	85	88	-	degree	5
	x axis, left ( $\phi=180^\circ$ )	$\theta_l$	85	88	-		
	y axis, up ( $\phi=90^\circ$ )	$\theta_u$	85	88	-		
	y axis, down ( $\phi=270^\circ$ )	$\theta_d$	85	88	-		
Gray Scale			-			6	
Cross Talk			-	1.8	%	7	



Product Specification

Notes :

1. Contrast ratio(CR) is defined mathematically as :

$$\text{Contrast ratio} = \frac{\text{Surface luminance with all white pixels}}{\text{Surface luminance with all black pixels}}$$

It is measured at center point(1)

2. Surface luminance is the luminance value at center 1 point(1) across the LCD surface 50cm from the surface with all pixels displaying white. For more information see FIG 6.

3. The variation in surface luminance ,  $\delta_{\text{WHITE}}$  is defined as

$$\delta_{\text{WHITE}} = \frac{\text{Maximum (P1,P2 .....P5)}}{\text{Minimum (P1,P2 .....P5)}}$$

For more information see [ Figure 6 ].

Figure 6. Luminance measuring point

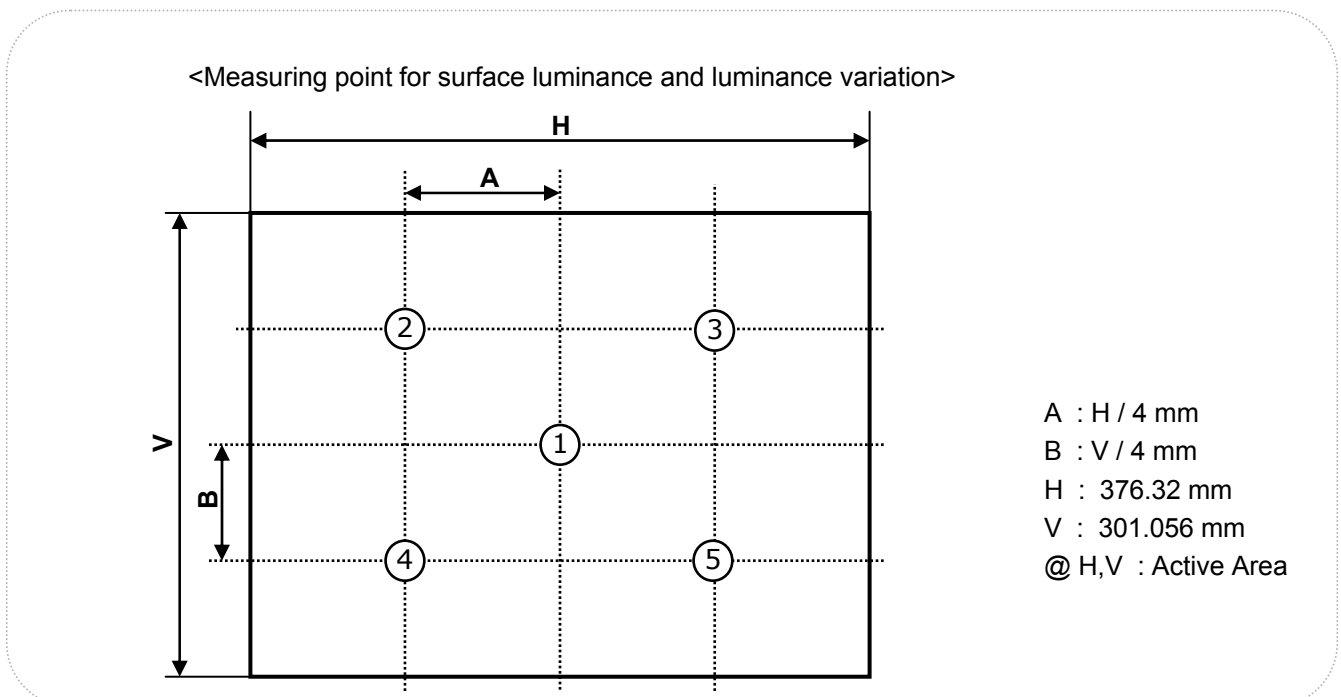



Product Specification

6. Gray scale specification

Table 12. Gray scale

Gray Level	Luminance [%] (Typ)	Gray Level	Luminance [%] (Typ)
L0	0.30	L143	33.2
L15	0.46	L159	42.4
L31	1.37	L175	52.4
L47	3.05	L191	62.4
L63	5.69	L207	73.0
L79	9.59	L223	83.6
L95	14.4	L239	93.0
L111	19.8	L255	100
L127	25.3		

7. Cross talk shall be measured at the V and H position. (Window size : 427×341pixels)  
For more information see FIG. 12.

$$\text{Cross talk} = \frac{(\text{Luminance at pattern A} - \text{Luminance at pattern B})}{\text{Luminance at pattern A}} \times 100\%$$

FIG. 12 Cross talk

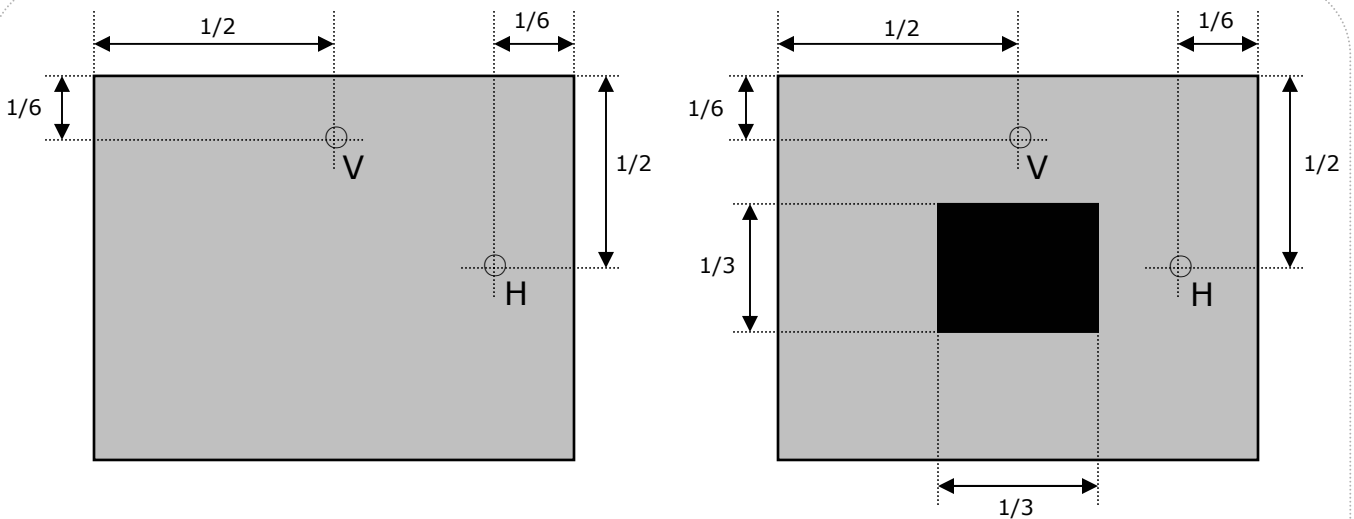

Pattern : A  
(Background : 127-Gray or White)

Pattern : B  
(Window : Black)  
(Background : 127-Gray or White)

Product Specification

### 5. Mechanical Characteristics

The contents provide general mechanical characteristics. In addition the figures in the next page are detailed mechanical drawing of the LCD.

Outline Dimension	Horizontal	404.20mm
	Vertical	330.0mm
	Depth	22.3 mm
Bezel Area	Horizontal	380.3 mm
	Vertical	305mm
Active Display Area	Horizontal	376.32mm
	Vertical	301.056mm
Weight	2,800g (Typ.) 2,940(Max)	
Surface Treatment	Hard coating(3H) Anti-glare treatment of the front polarizer	

Notes : Please refer to a mechanic drawing in terms of tolerance at the next page.

**Product Specification**

<FRONT VIEW>

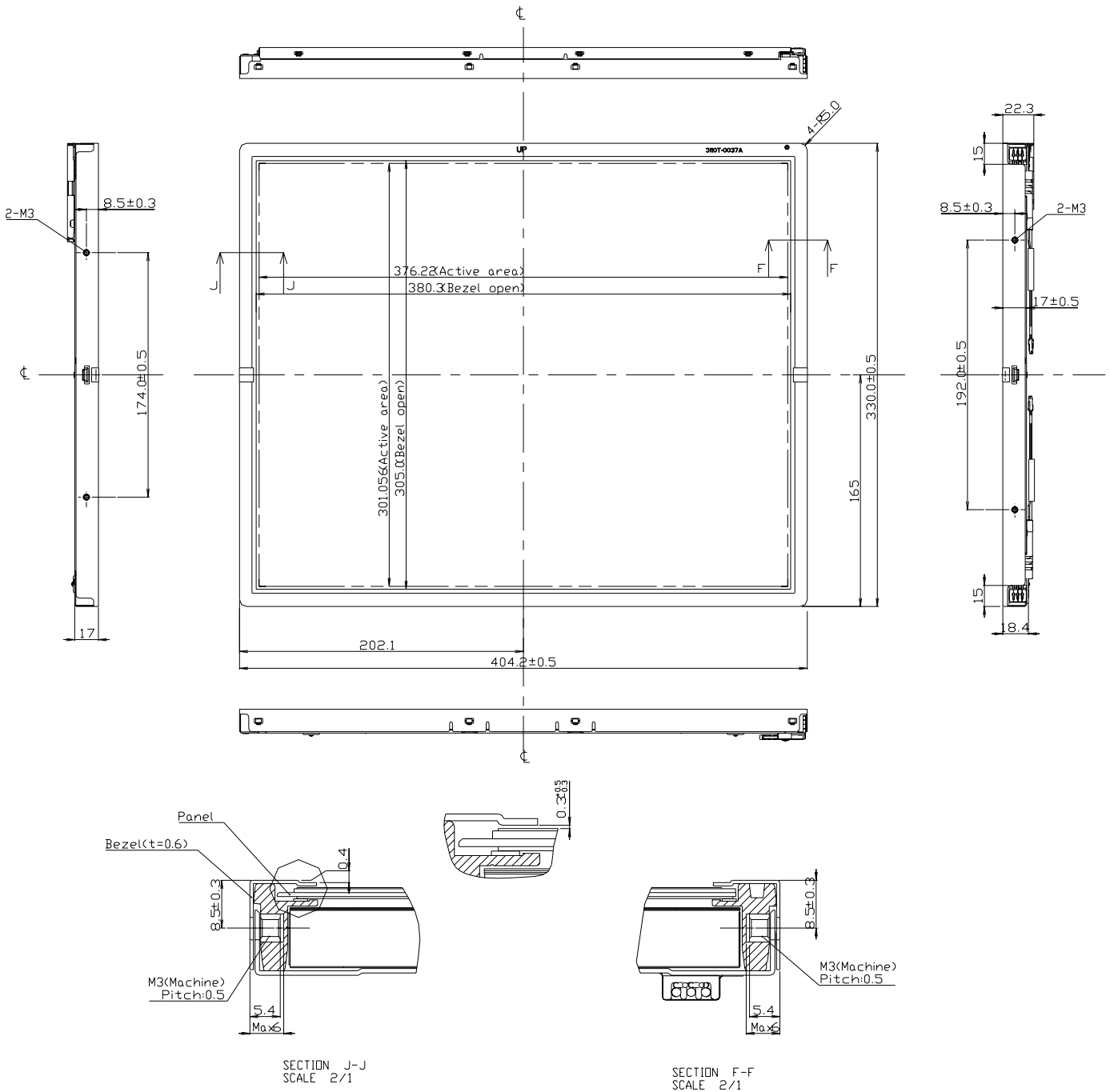

Product Specification

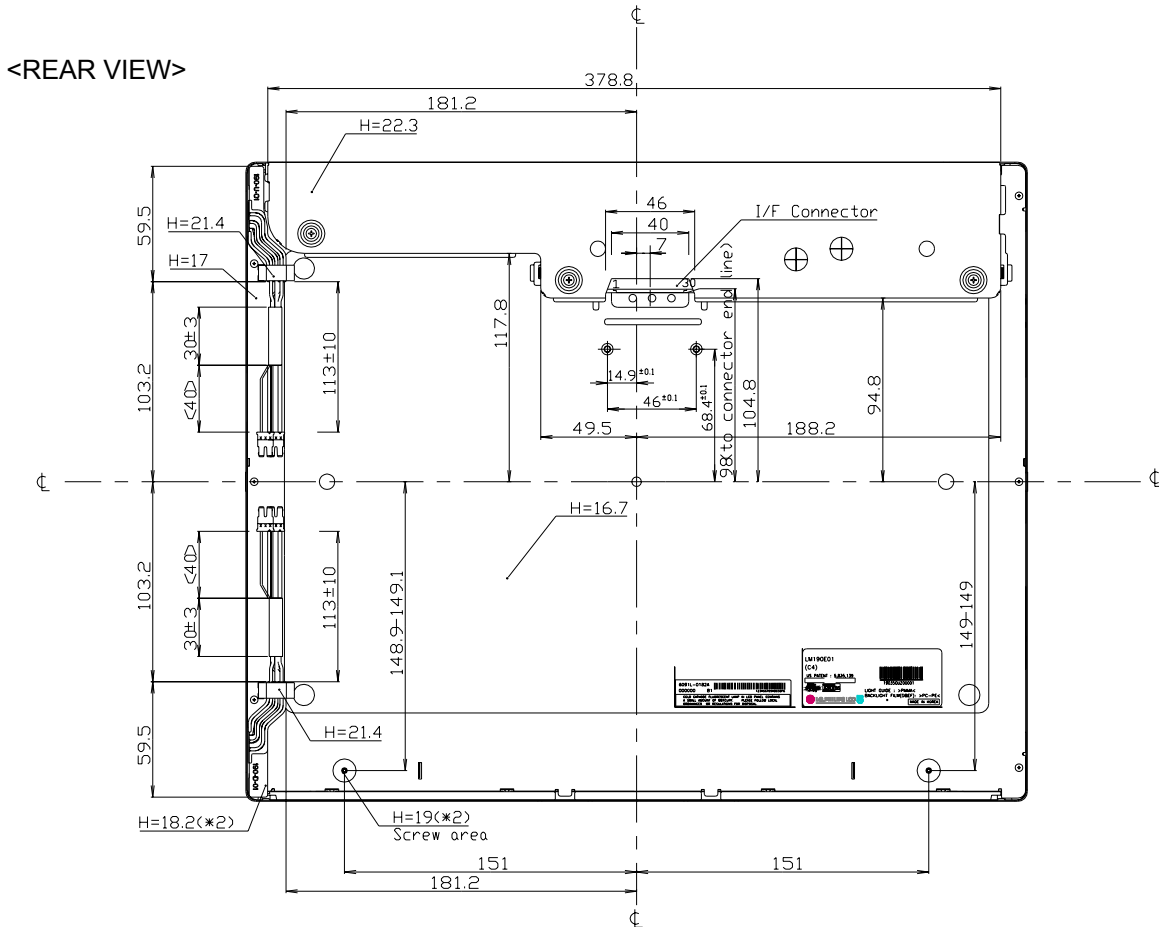

Notes

1. Backlight : 4 Cold Cathode Fluorescent Lamps
2. I/F Connector Specification : GT101-30S-HI16(LGC)/IN-30-BA 10(UJU)
3. Lamp Connector Specification  
- 1674817-1(AMP) or Compatible
4. Torque of user hole : 3.0~4.0kgf-cm
5. Tilt and partial disposition tolerance of display area as following  
(1) Y-Direction : |A-B| ≤ 1.0  
(2) X-Direction : |C-D| ≤ 1.0

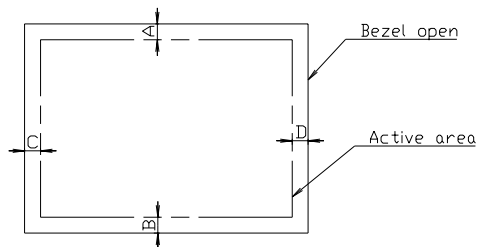

6. Lamp(CCFL) olt No. is marked at backlight connector

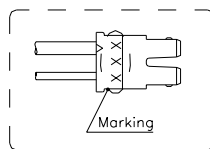

7. Do not wind conductive tape around the backlight wires
8. Unspecified tolerances to be ±0.5mm

Product Specification

## 6. Reliability

Environment test condition

No	Test Item	Condition
1	High temperature storage test	Ta= 60°C 240h
2	Low temperature storage test	Ta= -20°C 240h
3	High temperature operation test	Ta= 50°C 50%RH 240h
4	Low temperature operation test	Ta= 0°C 240h
5	Vibration test (non-operating)	Wave form : random Vibration level : 1.0G RMS Bandwidth : 10-500Hz Duration : X,Y,Z, 20 min One time each direction
6	Shock test (non-operating)	Shock level : 100G Waveform : half sine wave, 2ms Direction : ±X, ±Y, ±Z One time each direction
7	Altitude operating storage / shipment	0 - 10,000 feet(3048m) 0 - 40,000 feet(12,192m)

{ Result Evaluation Criteria }

There should be no change which might affect the practical display function when the display quality test is conducted under normal operating condition.

## 7. International Standards

### 7-1. Safety

- a) UL 60950, Third Edition, Underwriters Laboratories, Inc., Dated Dec. 11, 2000.  
Standard for Safety of Information Technology Equipment, Including Electrical Business Equipment.
- b) CAN/CSA C22.2, No. 60950, Third Edition, Canadian Standards Association, Dec. 1, 2000.  
Standard for Safety of Information Technology Equipment, Including Electrical Business Equipment.
- c) EN 60950 : 2000, Third Edition  
IEC 60950 : 1999, Third Edition  
European Committee for Electrotechnical Standardization(CENELEC)  
EUROPEAN STANDARD for Safety of Information Technology Equipment Including Electrical Business Equipment.

### 7-2. EMC

- a) ANSI C63.4 "Methods of Measurement of Radio-Noise Emissions from Low-Voltage Electrical and Electrical Equipment in the Range of 9kHz to 40GHz. "American National Standards Institute(ANSI), 1992
- b) C.I.S.P.R "Limits and Methods of Measurement of Radio Interface Characteristics of Information Technology Equipment." International Special Committee on Radio Interference.
- c) EN 55022 "Limits and Methods of Measurement of Radio Interface Characteristics of Information Technology Equipment." European Committee for Electrotechnical Standardization.(CENELEC), 1998  
( Including A1: 2000 )



## Product Specification

## 8. Packing

### 8-1. Designation of Lot Mark

#### a) Lot Mark

A	B	C	D	E	F	G	H	I	J	K	L	M
---	---	---	---	---	---	---	---	---	---	---	---	---

A,B,C : Inch

D : Year

E : Month

F : Panel Code

G : Factory Code

H : Assembly Code

I,J,K,L,M : Serial No

#### Note

##### 1. Year

Year	97	98	99	2000	2001	2002	2003	2004	2005	2006	2007
Mark	7	8	9	0	1	2	3	4	5	6	7

##### 2. Month

Month	Jan	Feb	Mar	Apr	May	Jun	Jul	Aug	Sep	Oct	Nov	Dec
Mark	1	2	4	4	5	6	7	8	9	A	B	C

##### 3. Panel Code

Panel Code	P1 Factory	P2 Factory	P3 Factory	P4 Factory	P5 Factory	Hydis Panel
Mark	1	2	3	4	5	H

##### 4. Factory Code

Factory Code	LPL Gumi	LPL Nanjing
Mark	K	C

##### 5. Serial No

Serial No.	1 ~ 99,999	100,000 ~
Mark	00001 ~ 99999	A0001 ~ A9999, - - - - , Z9999

## Product Specification

## b) Location of Lot Mark

Serial NO. is printed on the label. The label is attached to the backside of the LCD module.  
This is subject to change without prior notice.

**8-2. Packing Form**

- a) Package quantity in one box : 10 pcs
- b) Box Size : 374mm × 329mm × 311mm

**Product Specification****9. PRECAUTIONS**

Please pay attention to the followings when you use this TFT LCD module.

**9-1. MOUNTING PRECAUTIONS**

- (1) You must mount a module using holes arranged in four corners or four sides.
- (2) You should consider the mounting structure so that uneven force (ex. Twisted stress) is not applied to the module. And the case on which a module is mounted should have sufficient strength so that external force is not transmitted directly to the module.
- (3) Please attach the surface transparent protective plate to the surface in order to protect the polarizer. Transparent protective plate should have sufficient strength in order to resist external force.
- (4) You should adopt radiation structure to satisfy the temperature specification.
- (5) Acetic acid type and chlorine type materials for the cover case are not desirable because the former generates corrosive gas of attacking the polarizer at high temperature and the latter causes circuit break by electro-chemical reaction.
- (6) Do not touch, push or rub the exposed polarizers with glass, tweezers or anything harder than HB pencil lead. And please do not rub with dust clothes with chemical treatment. Do not touch the surface of polarizer for bare hand or greasy cloth.(Some cosmetics are detrimental to the polarizer.)
- (7) When the surface becomes dusty, please wipe gently with absorbent cotton or other soft materials like chamois soaks with petroleum benzene. Normal-hexane is recommended for cleaning the adhesives used to attach front / rear polarizers. Do not use acetone, toluene and alcohol because they cause chemical damage to the polarizer.
- (8) Wipe off saliva or water drops as soon as possible. Their long time contact with polarizer causes deformations and color fading.
- (9) Do not open the case because inside circuits do not have sufficient strength.

**9-2. OPERATING PRECAUTIONS**

- (1) The spike noise causes the mis-operation of circuits. It should be lower than following voltage :  
 $V = \pm 200\text{mV}$  (Over and under shoot voltage)
- (2) Response time depends on the temperature. (In lower temperature, it becomes longer.)
- (3) Brightness depends on the temperature. (In lower temperature, it becomes lower.)  
And in lower temperature, response time (required time that brightness is stable after turned on) becomes longer.
- (4) Be careful for condensation at sudden temperature change. Condensation makes damage to polarizer or electrical contacted parts. And after fading condensation, smear or spot will occur.
- (5) When fixed patterns are displayed for a long time, remnant image is likely to occur.
- (6) Module has high frequency circuits. Sufficient suppression to the electromagnetic interference shall be done by system manufacturers. Grounding and shielding methods may be important to minimize the interference.
- (7) Please do not give any mechanical and/or acoustical impact to LCM. Otherwise, LCM can not be operated its full characteristics perfectly.
- (8) A screw which is fastened up the steels should be a machine screw (if not, it causes metal foreign material and deal LCM a fatal blow)
- (9) Please do not set LCD on its edge.

### 9-3. ELECTROSTATIC DISCHARGE CONTROL

Since a module is composed of electronic circuits, it is not strong to electrostatic discharge. Make certain that treatment persons are connected to ground through wrist band etc. And don't touch interface pin directly.

### 9-4. PRECAUTIONS FOR STRONG LIGHT EXPOSURE

Strong light exposure causes degradation of polarizer and color filter.

### 9-5. STORAGE

When storing modules as spares for a long time, the following precautions are necessary.

- (1) Store them in a dark place. Do not expose the module to sunlight or fluorescent light. Keep the temperature between 5°C and 35°C at normal humidity.
- (2) The polarizer surface should not come in contact with any other object.  
It is recommended that they be stored in the container in which they were shipped.

### 9-6. HANDLING PRECAUTIONS FOR PROTECTION FILM

- (1) The protection film is attached to the bezel with a small masking tape.  
When the protection film is peeled off, static electricity is generated between the film and polarizer. This should be peeled off slowly and carefully by people who are electrically grounded and with well ion-blown equipment or in such a condition, etc.
- (2) When the module with protection film attached is stored for a long time, sometimes there remains a very small amount of glue still on the bezel after the protection film is peeled off.
- (3) You can remove the glue easily. When the glue remains on the bezel surface or its vestige is recognized, please wipe them off with absorbent cotton waste or other soft material like chamois soaked with normal-hexane.