

# **LQ080V3DG01**

## **TFT-LCD Module**

Spec. Issue Date: March 29, 2005

No: LCY-03094B

PREPARED BY: DATE <i>H. Yamachi 3.3.05</i>	<div style="text-align: center;"> <h1>SHARP®</h1> <p>MOBILE LIQUID CRYSTAL DISPLAY GROUP SHARP CORPORATION</p> <p><b>SPECIFICATION</b></p> </div>	SPEC No. LCY-03094B
APPROVED BY: DATE		FILE No.
		ISSUE March.29.2005
		PAGE 20 Pages
		APPLICABLE DIVISION  MOBILE LCD DESIGN CENTER MOBILE LIQUID CRYSTAL DISPLAY GROUP

**DEVICE SPECIFICATION for**  
**Color TFT (Thin Film Transistor) LCD Module**

Model No.  
**LQ080V3DG01**

CUSTOMER'S APPROVAL

DATE \_\_\_\_\_

BY \_\_\_\_\_

PRESENTED BY *Hiroshi Hamada*

H. HAMADA  
 DEPARTMENT GENERAL MANAGER  
 ENGINEERING DEPARTMENT I  
 MOBILE LCD DESIGN CENTER  
 MOBILE LIQUID CRYSTAL DISPLAY GROUP  
 SHARP CORPORATION



**NOTICE**

This publication is the proprietary of SHARP and is copyrighted, with all rights reserved. Under the copyright laws, no part of this publication may be reproduced or transmitted in any form or by any means, electronic or mechanical for any purpose, in whole or in part, without the express written permission of SHARP. Express written permission is also required before any use of this publication may be made by a third party.

The application circuit examples in this publication are provided to explain the representative applications of SHARP's devices and are not intended to guarantee any circuit design or permit any industrial property right or other rights to be executed. SHARP takes no responsibility for any problems related to any industrial property right or a third party resulting from the use of SHARP's devices, except for those resulting directly from device manufacturing processes.

The devices in this publication are designed for AV equipment use.

The appropriate design measures should be taken to ensure reliability and safety when SHARP's devices are used for equipment such as:

- Transportation control and safety equipment(i.e. aircraft, trains, automobiles, etc.)
- Traffic signals                      • Gas leakage sensor breakers
- Alarm equipment                      • Various safety devices etc.

SHARP's devices shall not be used for equipment that requires extremely high level of reliability, such as:

- Military and space applications                      • Nuclear power control equipment
- Medical equipment for life support

SHARP takes no responsibility for any problems caused by usage of SHARP's devices for any "specific" applications other than those recommended by SHARP.

Contact and consult with a SHARP representative if there are any questions about the contents of this publication.

## 1 Applicable TFT-LCD module

This specification applies to the color TFT-LCD module, LQ080V3DG01.

## 2 Overview

This module is a color active matrix transmissive LCD module incorporating amorphous silicon TFT (Thin Film Transistor).

It is composed of a color TFT-LCD panel, driver ICs, control circuits and power supply circuitry and a backlight unit. Graphics and texts can be displayed on a 640 x RGB x 480 dots panel with 262,144 colors by feeding 18 bit data signal (6bit/each of R,G,B), 4(four) timing signals, +3.3V or +5V DC power supply for TFT-LCD and AC power supply for backlight.

(Note: Backlight-driving DC/AC inverter is not built in this module.)

- Very fine images with stripe aligned 307,200 pixels on 8 inch diagonal screen
- Color display capability of 262,144 colors with 18 bit data signal(6 bits for each RGB)
- Adapting a wide viewing angle technology [best viewing angle: 6 o'clock direction]
- High contrast, thanks to active matrix drive system
- Low reflection with AG(Anti Glare) polarizing filter
- Light and slim compact module achieved by COG assemble technology
- Natural coloring reproducibility by employing normally-white-mode, which has good nature in coloring
- Image inversion both horizontally and vertically
- This module adapt to RoHS compliance.

## 3 Mechanical Specifications

items	specifications	unit
Display size (Diagonal)	20.3 (8")	cm
Active display area	162.2(H) x 121.7(V)	mm
Pixel format	640(H) x RGB x 480(V)	dot
	(1 pixel=R+G+B dots)	-
Pixel pitch	0.2535(H) x 0.2535(V)	mm
Pixel configuration	R,G,B vertical stripe	-
LCD mode	Normally white/Twisted Nematic	-
Dimension *1	183.0(W) x 141.0(H) x 14.0 (D)	mm
Mass	390±20	g

\*1. Protrusion such as backlight harness and positioning boss are not included.

Fig.1 shows dimensions of the module.

Fig.2 shows the assemble configuration.

## 4 Input Signal Assignment

### 4.1 TFT-LCD Panel driving section

Employed connector: IL-FPR-32S-VF-N1 (JAE Limited)

Pin No.	Symbol	Function	Polarity
1	GND	—	
2	CK	Clock signal for sampling each datum	
3	Hsync	Horizontal Sync signal	Negative
4	Vsync	Vertical Sync signal	Negative
5	GND		
6	R0	RED Data signal (LSB)	
7	R1	RED Data signal	
8	R2	RED Data signal	
9	R3	RED Data signal	
10	R4	RED Data signal	
11	R5	RED Data signal (MSB)	
12	GND		
13	G0	GREEN data signal (LSB)	
14	G1	GREEN data signal	
15	G2	GREEN data signal	
16	G3	GREEN data signal	
17	G4	GREEN data signal	
18	G5	GREEN data signal (MSB)	
19	GND		
20	B0	BLUE data signal (LSB)	
21	B1	BLUE data signal	
22	B2	BLUE data signal	
23	B3	BLUE data signal	
24	B4	BLUE data signal	
25	B5	BLUE data signal (MSB)	
26	GND		
27	ENAB	Data Enable signal (Control signal for image location in horizontal direction)	[Note 1]
28	Vcc	Power supply in	
29	Vcc	Power supply in	
30	R/L	Horizontal scanning direction control signal (Rightwards/Leftwards)	[Note 2]
31	U/D	Vertical scanning direction control signal (Upwards/downwards)	[Note 2]
32	GND		

The shield case is internally grounded to GND of the module.

#### [Note 1]

The horizontal display location is designated and controlled by rising timing of ENAB signal.

However if ENAB signal is fixed to “Low”, display location is designated by the default setting in the module.

(Don't use the module by fixing ENAB to “High”) .....See: Chapter 7-2

[Note 2]



(R/L=High, U/D=High)

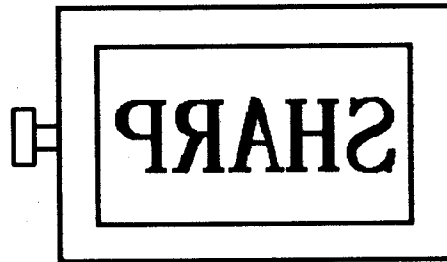

(R/L=Low, U/D=High)

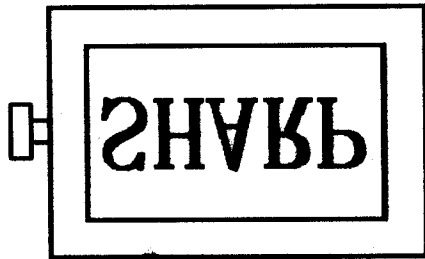

(R/L=High, U/D=Low)

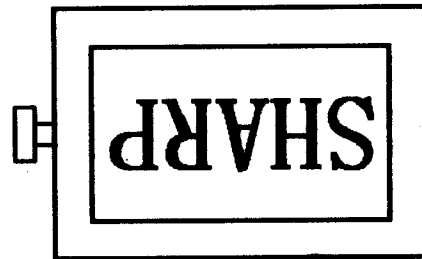

(R/L=Low, U/D=Low)

4.2 Backlight section

Employed connector: BHR-02VS-1N (JST)

CN2

Adapted connector: SM02 (8.0) B-BHS-1N (JST)

Pin no.	Symbol	Function
1	V <sub>HIGH</sub>	Power supply for lamp (High voltage side)
2	V <sub>LOW</sub>	Power supply for lamp (Low voltage side)

5 Absolute Maximum Ratings

Parameter	Symbol	Condition	Ratings	Unit	Remark
Input voltage	V <sub>I</sub>	T <sub>a</sub> =25°C	-0.3 ~ +6	V	[Note 1]
Supply voltage	V <sub>CC</sub>	T <sub>a</sub> =25°C	0 ~ +6	V	-
Storage temperature	T <sub>stg</sub>	-	- 25 ~ +70	°C	[Note 2]
Operating temperature (Panel surface)	T <sub>opp</sub>	-	0 ~ +70	°C	
Operating temperature (Ambient)	T <sub>opa</sub>	-	0 ~ +55	°C	

[Note 1] CK, R0 ~ R5, G0 ~ G5, B0 ~ B5, Hsync, Vsync, ENAB, R/L and U/D

[Note 2] Humidity: Less than 95%RH at T<sub>a</sub> = 40°C and

Maximum wet-bulb temperature must not exceed 39°C at T<sub>a</sub>>40°C,  
with no condensation.

6 Electrical characteristics

6.1 TFT-LCD Panel driving section

Ta=25°C

Parameter	Symbol	Min	Typ	Max	Unit	Remarks
Supply voltage	V <sub>CC</sub>	+3.0	+3.3	+3.6	V	[Note1]
	V <sub>CC</sub>	-4.5	+5.0	+5.5	V	
Current dissipation	I <sub>CC</sub>	-	320	440	mA	[Note2] V <sub>CC</sub> =3.3V
	I <sub>CC</sub>	-	220	300	mA	[Note2] V <sub>CC</sub> =5.0V
Allowed input ripple voltage	V <sub>RF</sub>	-	-	100	mV p-p	V <sub>CC</sub> =+5V
Input voltage ("Low" state)	V <sub>IL</sub>	-0.3	-	0.9	V	[Note3]
Input voltage ("High" state)	V <sub>IH</sub>	2.3	-	5.5	V	
Input leakage current (low)	I <sub>OL1</sub>	-	-	1.0	μA	V <sub>I</sub> =0V [Note4]
	I <sub>OL2</sub>	-	-	80.0	μA	V <sub>I</sub> =0V [Note5]
Input leakage current (High)	I <sub>OH1</sub>	-	-	1.0	μA	V <sub>I</sub> =V <sub>CC</sub> [Note6]
	I <sub>OH2</sub>	-	-	80.0	μA	V <sub>I</sub> =V <sub>CC</sub> [Note7]

[Note1]

V<sub>CC</sub> turn-on/off conditions

- 0 < t<sub>1</sub> = 15ms
- 0 < t<sub>2</sub> = 20ms
- 0 < t<sub>3</sub> = 1s
- 1s < t<sub>4</sub>

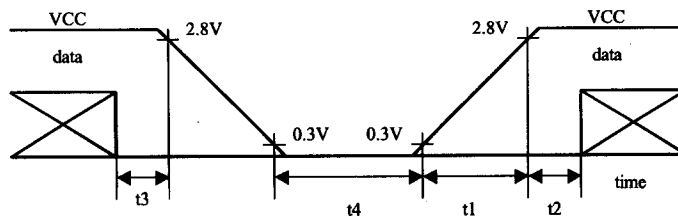

V<sub>CC</sub>-dip conditions

- 1) At 2.7V = V<sub>CC</sub> < 3.0V  
t<sub>d</sub> = 10ms
- 2) At V<sub>CC</sub> < 2.7V  
V<sub>CC</sub> dip conditions should also follow the V<sub>CC</sub> turn-on/off conditions

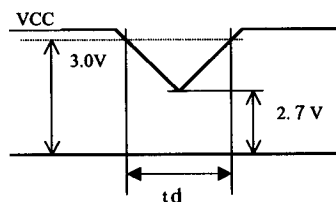

[Note2] Current dissipation (Typ.): When Monochrome 16 level-gray-bar pattern is displayed (Figure below, Refer Page 10 for details of RGB)

Current dissipation (Max.): When GS3 and GS10 gray bar are displayed alternately.

[Note3] CK, R0~R5, G0~G5, B0~B5, Hsync, Vsync, ENAB, R/L and U/D

[Note4] CK, R0~R5, G0~G5, B0~B5, Hsync, Vsync and ENAB

[Note5] R/L and U/D

[Note6] CK, R0~R5, G0~G5, B0~B5, Hsync and Vsync,

[Note7] ENAB, R/L and U/D

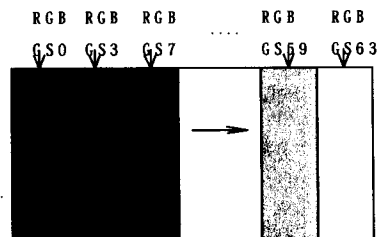



## 6.2 Backlight driving Section

Ta=25°C

Parameter	Symbol	Min.	Typ.	Max.	Unit	Remarks
Lamp voltage	VL	770	860	950	V rms	IL=6.0mA rms
Lamp current	IL	4.0	6.0	7.0	mA rms	at normal operation
Lamp frequency	fL	35	-	70	KHz	Recommend 52kHz
Kick-off voltage [Note6-1]	Vs	-	-	2050	V rms	Ta=-10°C [Note6-2]
		-	-	2000		Ta=25°C [Note6-2]
		-	-	3300		Ta=-10°C [Note6-3]
		-	-	3200		Ta=25°C [Note6-3]

(Inverter: HARISON TOSHIBA LIGHTING CORPORATION Type HIU-766 (13.5pF) is used at drive frequency f=52 kHz)

Caution: Use Inverter providing symmetrical sine-wave in positive/negative polarity with no spike.

[Note6-1] Connect Module's metal shield case to GND of inverter circuit.

[Note6-2] The voltage at the output of inverter circuitry

[Note6-3] The voltage at the output of transformer built in inverter circuitry

## 7 Timing Characteristics of Input Signals

Timing diagrams of input signal are shown in Fig.4.

## 7.1 Timing Characteristics

Parameter	Symbol	Min.	Typ.	Max.	Unit	
Clock	Frequency	1/Tc	-	25.18	28.33	MHz
	"High" time	Tch	5	-	-	ns
	"Low" time	Tcl	10	-	-	ns
Data	Setup time	Tds	5	-	-	ns
	Hold time	Tdh	10	-	-	ns
Hsync	Period	TH	30.00	31.78		μs
			770	800	900	clock
	Pulse width	THp	2	96	200	clock
Vsync	Period	TV	515	525	560	line
	Pulse width	TVp	1	-	34	line
Horizontal display period	THd	640	640	640	clock	
Phase difference between Hsync and clock	THc	10	-	Tc-10	ns	
Phase difference between Hsync and Vsync	TVh	0	-	TH-THp	clock	
Vertical display period	TVd	480	480	480	line	

Note) In case of lower frequency, the deterioration of display quality, flicker etc., may occur.

## 7.2 Display Position in horizontal direction

Display position in horizontal direction is designated by rising timing of ENAB signal.

Parameter	Symbol	MIN	TYP	MAX	Unit	Note
ENAB signal	Setup time	Tes	5	-	Tc-10	ns
	Pulse width	Tep	2	640	640	clock
Phase difference between Hsync and ENAB signal	THe	44	-	TH-664	clock	

When ENAB is fixed to "Low", the horizontal display will start from the clock C104 (clock) as shown in Fig.4. When the phase difference is not greater than 104 clock, hold ENAB terminal in "High" state for more than (104-THe), otherwise display will start from C104 (clock).

## 7.3 Display position in vertical direction

Display start position in vertical direction is fixed to the 34th line.

The ENAB signal does not relate to Vertical display position.

7.4 Input signal and display on the screen

Display position of input data

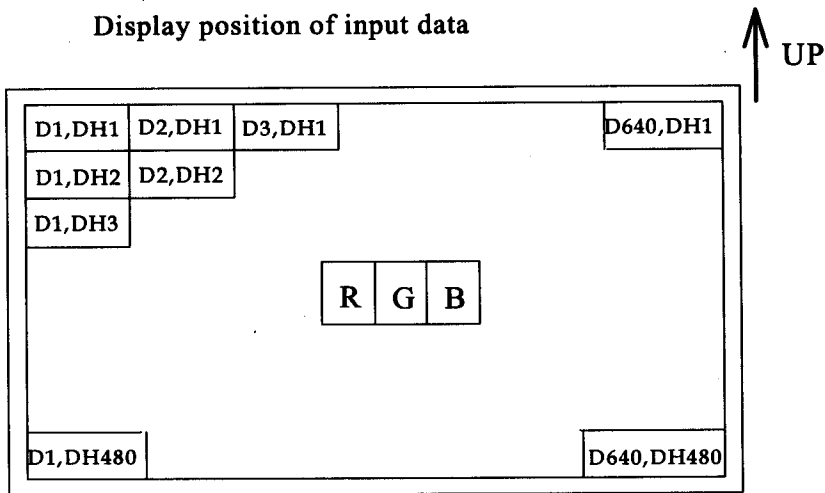

8 Input Signals, Basic Display Colors and Gray Scale of Each Color

	Colors & Gray scale	Data signal																		
		Gray Scale	R0	R1	R2	R3	R4	R5	G0	G1	G2	G3	G4	G5	B0	B1	B2	B3	B4	B5
Basic Color	Black	-	0	0	0	0	0	0	0	0	0	0	0	0	0	0	0	0	0	0
	Blue	-	0	0	0	0	0	0	0	0	0	0	0	0	1	1	1	1	1	1
	Green	-	0	0	0	0	0	0	0	1	1	1	1	1	0	0	0	0	0	0
	Cyan	-	0	0	0	0	0	0	0	1	1	1	1	1	1	1	1	1	1	1
	Red	-	1	1	1	1	1	1	1	0	0	0	0	0	0	0	0	0	0	0
	Magenta	-	1	1	1	1	1	1	1	0	0	0	0	0	0	0	1	1	1	1
	Yellow	-	1	1	1	1	1	1	1	1	1	1	1	1	0	0	0	0	0	0
	White	-	1	1	1	1	1	1	1	1	1	1	1	1	1	1	1	1	1	1
Gray Scale of Red	Black	GS0	0	0	0	0	0	0	0	0	0	0	0	0	0	0	0	0	0	0
	↑	GS1	1	0	0	0	0	0	0	0	0	0	0	0	0	0	0	0	0	0
	Darker	GS2	0	1	0	0	0	0	0	0	0	0	0	0	0	0	0	0	0	0
	↑	↓				↓					↓						↓			
	↓	↓				↓					↓						↓			
	Brighter	GS61	1	0	1	1	1	1	0	0	0	0	0	0	0	0	0	0	0	0
	↓	GS62	0	1	1	1	1	1	0	0	0	0	0	0	0	0	0	0	0	0
Red	GS63	1	1	1	1	1	1	0	0	0	0	0	0	0	0	0	0	0	0	
Gray Scale of Green	Black	GS0	0	0	0	0	0	0	0	0	0	0	0	0	0	0	0	0	0	
	↑	GS1	0	0	0	0	0	0	1	0	0	0	0	0	0	0	0	0	0	
	Darker	GS2	0	0	0	0	0	0	0	1	0	0	0	0	0	0	0	0	0	
	↑	↓				↓					↓						↓			
	↓	↓				↓					↓						↓			
	Brighter	GS61	0	0	0	0	0	0	1	0	1	1	1	1	0	0	0	0	0	
	↓	GS62	0	0	0	0	0	0	0	1	1	1	1	1	0	0	0	0	0	
Green	GS63	0	0	0	0	0	0	1	1	1	1	1	1	0	0	0	0	0		
Gray Scale of Blue	Black	GS0	0	0	0	0	0	0	0	0	0	0	0	0	0	0	0	0	0	
	↑	GS1	0	0	0	0	0	0	0	0	0	0	0	0	1	0	0	0	0	
	Darker	GS2	0	0	0	0	0	0	0	0	0	0	0	0	0	1	0	0	0	
	↑	↓				↓					↓					↓				
	↓	↓				↓					↓					↓				
	Brighter	GS61	0	0	0	0	0	0	0	0	0	0	0	0	1	0	1	1	1	
	↓	GS62	0	0	0	0	0	0	0	0	0	0	0	0	0	1	1	1	1	
Blue	GS63	0	0	0	0	0	0	0	0	0	0	0	0	1	1	1	1	1		

0: Low level voltage, 1: High level voltage

Each basic color can be displayed in 64 gray scales from 6 bit data signals. According to the combination of total 18 bit data signals, the 262,144-color display can be achieved on the screen.

9 Optical Specification

Ta=25°C, Vcc=+3.3V

Parameter		Symbol	Condition	Min.	Typ.	Max.	Unit	Remark
Viewing angle Range	Horizontal	∠1,∠2	CR=5	60	65	-	° (Deg.)	[Note9-1,4]
	Vertical	∠11		60	65	-	° (Deg.)	
		∠12		50	55	-	° (Deg.)	
Contrast ratio		CR max	Best viewing angle	60	250	-	-	[Note9-2]
Response time	Rise	Tr	∠ = 0°	-	30	60	ms	[Note9-3]
	Fall	Td		-	50	100	ms	
Chromaticity of white		x	IL=6mA rms	0.263	0.313	0.363	-	[Note9-4]
		y		0.279	0.329	0.379	-	
Luminance		Y	∠ = 0°	320	380	-	cd/m <sup>2</sup>	
Lamp lifetime	+25°C	-	Continuous	10,000	-	-	hour	[Note9-5]
	-10°C	-	On-Off cycle	2,000	-	-	cycle	[Notr9-6]

Lamp test in the module is made with the inverter type "HIU-766(13.5pF) at 52kHz

The optical specifications are measured 30 minute after turning lamp on and in a dark room or equivalent condition, according to the method shown in Fig.9-1, 2 below.

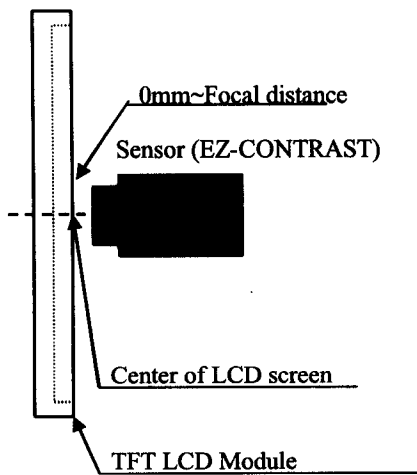

Fig.9-1 Measuring setup for Viewing angle and Contrast ratio

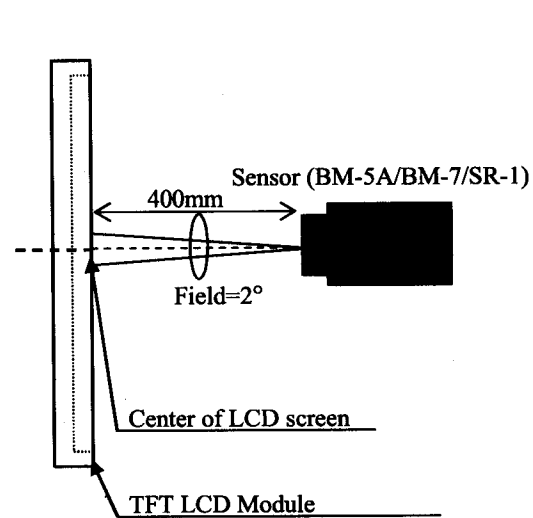
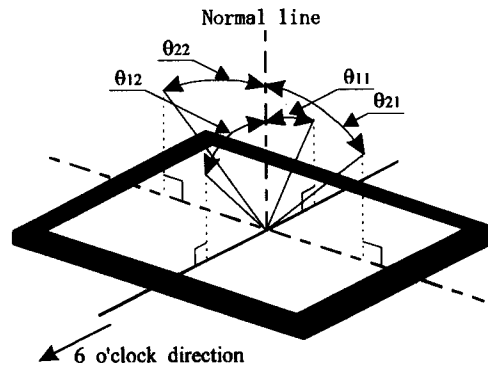

Fig.9-2 Measuring setup for Luminance, Chromaticity and Response time  
(BM-7 is used for Luminance, SR-1 is for response)

[Note9-1] Definitions of viewing angle range:



[Note9-2] Definition of contrast ratio:

The contrast ratio is defined as the following.

$$\text{Contrast Ratio (CR)} = \frac{\text{Luminance (brightness) with all pixels white}}{\text{Luminance (brightness) with all pixels black}}$$

[Note9-3] Definition of response time:

The response time is defined as the following figure and shall be measured by switching the input signal between "black" and "white" alternatively.

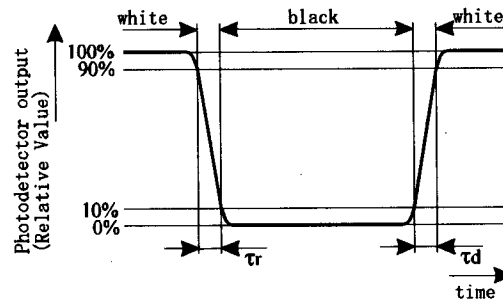

[Note9-4] This parameter should be measured at the center of the screen and 30 minutes after turn-on.  
 Inverter frequency: 52 kHz  
 The characteristics are measured when the driver circuit is not powered.

[Note9-5] The data for lamp is for your reference, because lamp is consumable component.

a) Lamp life time is defined by either 1 or 2 below.

(Continuous turning on at  $T_a=25^\circ\text{C}$ ,  $I_L=6\text{ mA rms}$ )

1. Brightness becomes 50% of the initial value under standard condition.
2. Kick-off voltage at minimum operation temperature exceeds 2050Vrms (at output of inverter) or 3300V (at transformer in the inverter)

b) If the module is operated in low ambient temperature environment for long time, the lamp exhaustion is accelerated and the brightness becomes rapidly lower.

You are recommended not to continuously use the module in low temperature.

(Continuous operating in low temp. condition may reduce the brightness to half of the original brightness within one month)

In case of such usage, periodical lamp exchange is recommended.

[Note9-6] The life is defined as the number of ON-OFF cycle that lamp is operated as shown below and its luminance on LCD panel becomes 50% of original value.

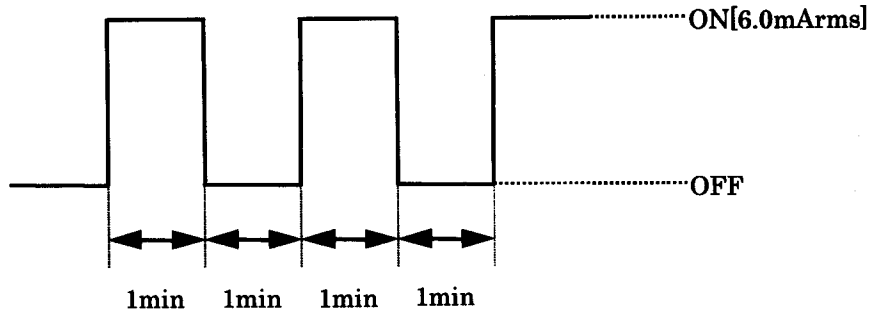

## 10 Display Qualities

Please refer to the Outgoing Inspection Standard.

## 11 Handling Instruction

### 11.1 Assembling the module

- 1) This TFT-LCD module has four screw holes at each corner to fix it to customer's product. Nominal 2.6mm tapping screw (Screwing torque: 0.3~0.4 N·m) is recommended. Mount the module on same plane and don't apply stress such as bow or crook. In general, a tapping screw assures to be fastened only one time, therefore special care should be taken when screw is fasten more than one time. The problem caused by fastening screw more than one time is no scope of warranty. Careful design is required to prevent direct pressure to the module resulting from pressing touch panel switch in product, otherwise it may cause distorted image on the screen.
- 2) Connection/disconnection of the module's input connector shall be made while power is off.
- 3) Make sure to connect module's metal shield case to GND of inverter circuit. If its connection is not made perfectly, some of the following problems may occur.
  - a) Increase of noise caused by backlight
  - b) Unstable output from inverter circuit
  - c) Possibly over-heat in some section

### 11.2 Instruction for assembling

Since the front polarizer is easily damaged, pay attention to avoid rubbing with something hard or sharp. A protective film "Laminator" is attached on the module screen to avoid scratch and/or dust. You are recommended remove the "Laminator" just before you embed the module into your products, paying attention to avoid electrostatic damage as followings.

#### A) Work Environment

Since removing laminator may causes electrostatic charge that tends to attract dust, the following work environment would be desired.

- a) Floor: Conductive treatment having 1M $\Omega$  resistance onto floor's tile
- b) The room free from dust coming from outdoor environment, and put an adhesive mat at entrances
- c) Humidity from 50% to 70% and temperature from 15°C to 27°C are desirable.
- d) Worker should ware conductive shoes, conductive fatigue, conductive glove and earth wrist band.

### B) Instruction for working

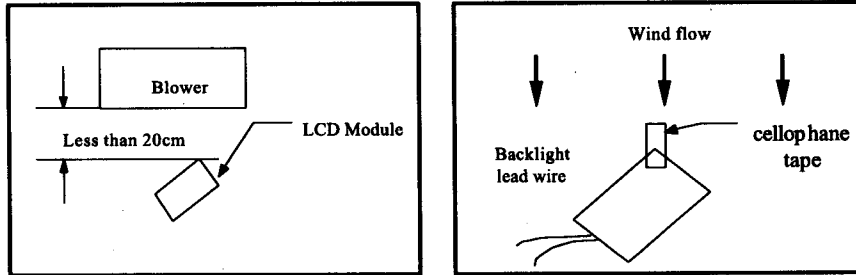

- a) Wind direction of an electrostatic discharging blower should slightly downward to properly blow the module. The distance between the blower and the module should be less than 20cm. Also, pay attention to the direction of the module. [See the above]
- b) To prevent polarizer from scratching, adhesive tape (cellophane tape) should be stuck at the part of laminator sheet, which is closed to blower. [See the above]
- c) Pull slowly adhesive tape to peel the laminator off, with spending more than 5 second.
- d) The module without laminator should be moved to the next process to prevent dust.
- e) How to eliminate dust on polarizer.
  - > Blow dust away by N<sub>2</sub> blower having measures of electrostatics
  - > Since the front polarizer is easily damaged, wiping dust off is not adequate.
 If the polarizer is soiled, it is suggested to peel dust off by using adhesive surface of adhesive tape.

When the metal section [shield case or shield back case] is soiled, wipe it off with dry and soft cloth. If not so easy, breathe upon it then wipe off. If the water droplet or fat is left for long term, it may cause stain or tarnish, it should be wipe off immediately.

Since TFT-LCD panel is made of glass substrate, dropping the panel or banging it against hard objects may cause cracking or fragmentation.

Since CMOS LSIs are incorporated in this module, please pay special care to electrostatic while handling it, and earth human body.

### 11.3 Caution in product design

The notes and cautions below should be followed when product is designed with this module.

The module should be protected with cover to prevent salt content and/or water droplet.

Take enough shielding countermeasure not to interfere to peripheral electronic device.

11.4 Others

The LCD has the nature that its performance is degradation by ultra-violet light. Don't leave the LCD module in direct sunlight or strong ultra violet ray.

If stored at the temperatures lower than the rated storage temperature, the LC may freeze and it may cause LCD panel damage. If storage temperature exceeds the specified rating, the molecular orientation of the LC may change to that of a liquid, and they may not revert to their original state. Store the module in normal room temperature.

The inductive loss caused by routing of lamp lead wire, which is closed to conductive section, may require the kick-off voltage greater than specified kick-off voltage.

The liquid crystal may leak out when the LCD is broken. If the liquid crystal drip into the eyes or mouth washes it out immediately.

The caution to other ordinal electronic component should be followed also.

12 Packing Form

12.1 Fig.3 shows packaging form.

12.2 Carton stock conditions

- a) Maximum number of Carton being stuck: 8
- b) Maximum number of product contained: 20 Unit
- c) Carton size: 480mm (W) x 381mm (H) x 247mm (D)
- d) Total mass (for 20Unit): Approximately 9.5kg
- e) Carton stock environment:
  - 1) Temperature: 0 ~ 40°C
  - 2) Humidity: Up to 60%RH
  - 3) Ambiance: No gases bite into electronic components and wiring materials
  - 4) Period: Approximately 3month
  - 5) Unpacking: To prevent LCD module from damaging by ESD, unpack the module with effective measure after controlling humidity 50%RH or more.

13 Marking of product name

13.1 Serial No. indication

Serial No. is indicated by labeling. The location is given in Fig.1 Outline dimension.

Indicated contents:

<b>LQ080V3DG01 S   XXXXXXXXXX</b>
-----------------------------------

Model name	Serial No.
------------	------------

Serial No. contents 1st digit:	last digit of produced year (ex. 2003 → "3")
2nd digit:	Produced month 1, 2, 3 ~ 9, X, Y, Z
3rd ~ 8th digit:	Sequential number 000001 ~
9th digit:	Interoffice control code



14 Miscellaneous

- a) Variable resistor has been set optimally before shipment, so do not change any adjusted value. If adjusted value is changed, the specification may be not satisfied.
- b) Don't disassemble this module, it may cause malfunction.
- c) Image retention may occur when the fixed image is display for long time.
- d) Input connector [32 pin, IL-FPR-VF (JAE Inc.)]
  - 1) Corresponding FRC: Shown below
  - 2) Terminal holding force: 0.9 N/pin or more  
 [Pull each terminal at the speed 25±3 mm/minute]
  - 3) Durability in connect/disconnect: 2 times of initial value or less  
 [Difference of contact resistance after 20 times of connect/disconnect test are made with corresponding FPC]

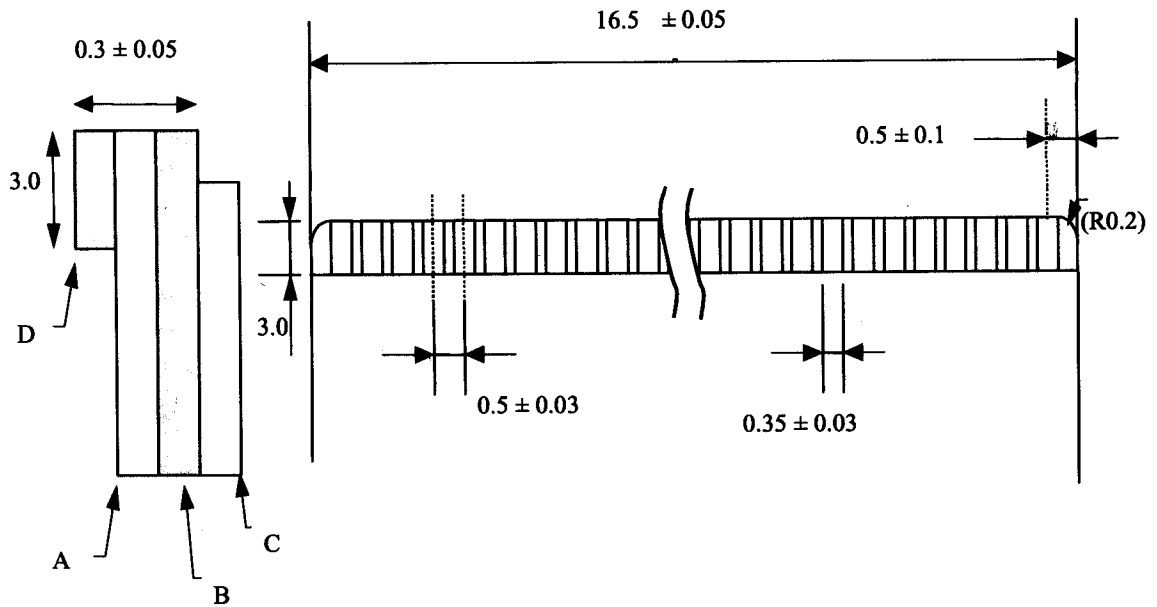

No.	Description	Material
A	Base film	Polyimide or the equivalent to it [t=25μm]
B	Copper conductor	Copper conductor [t=35μm], Gold plate [t=2μm]
C	Cover lay	Polyimide or the equivalents to it
D	Reinforcing board	Polyester, Polyimide or the equivalents to them [t=188μm]

15 Reliability Test Items

Note: The condition of temperature is the operation temperature given in Absolute maximum rating.

No.	Test parameter	Conditions
1	High temperature storage test	Leaves the module at Ta=75°C for 240h
2	Low temperature storage test	Leaves the module at Ta=-25°C for 240h
3	High temperature & high humidity operation test	Operates the module at Ta=40°C; 90~95%RH for 240h (No condensation)
4	High temperature operation test	Operates the module with +70°C at panel surface for 240h
5	Low temperature operation test	Operates the module at Ta=0°C for 240h
6	Strength against ESD	±200V 200pF [0Ω] one time for each terminal
7	Shock test (non- operating)	980m/s <sup>2</sup> ·6ms, 3 time for direction ±X, ±Y, ±Z (JIS C0041, A-7, Condition C)
8	Vibration test (non- operating)	Frequency: 8 ~33.3Hz, Amplitude: 1.3mm Frequency: 33.3Hz ~ 400Hz, Gravity:28.4m/s <sup>2</sup> Test period : 15 minute 2 hour for each direction of X,Z direction, 4 hour for Y direction (Total 8hour) (Note) [JIS D1601]
9	Thermal shock test	-25°C ~ +70°C /5 cycle [0.5h] [0.5h]

[Result Evaluation Criteria]

Under the display quality test conditions with normal operation state, these shall be no change which may affect practical display function.

[Note] The directions of X, Y, Z are defined as below:

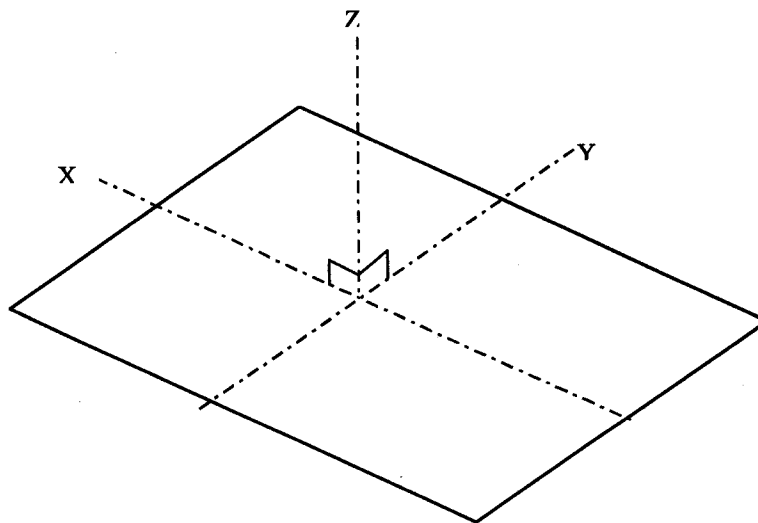

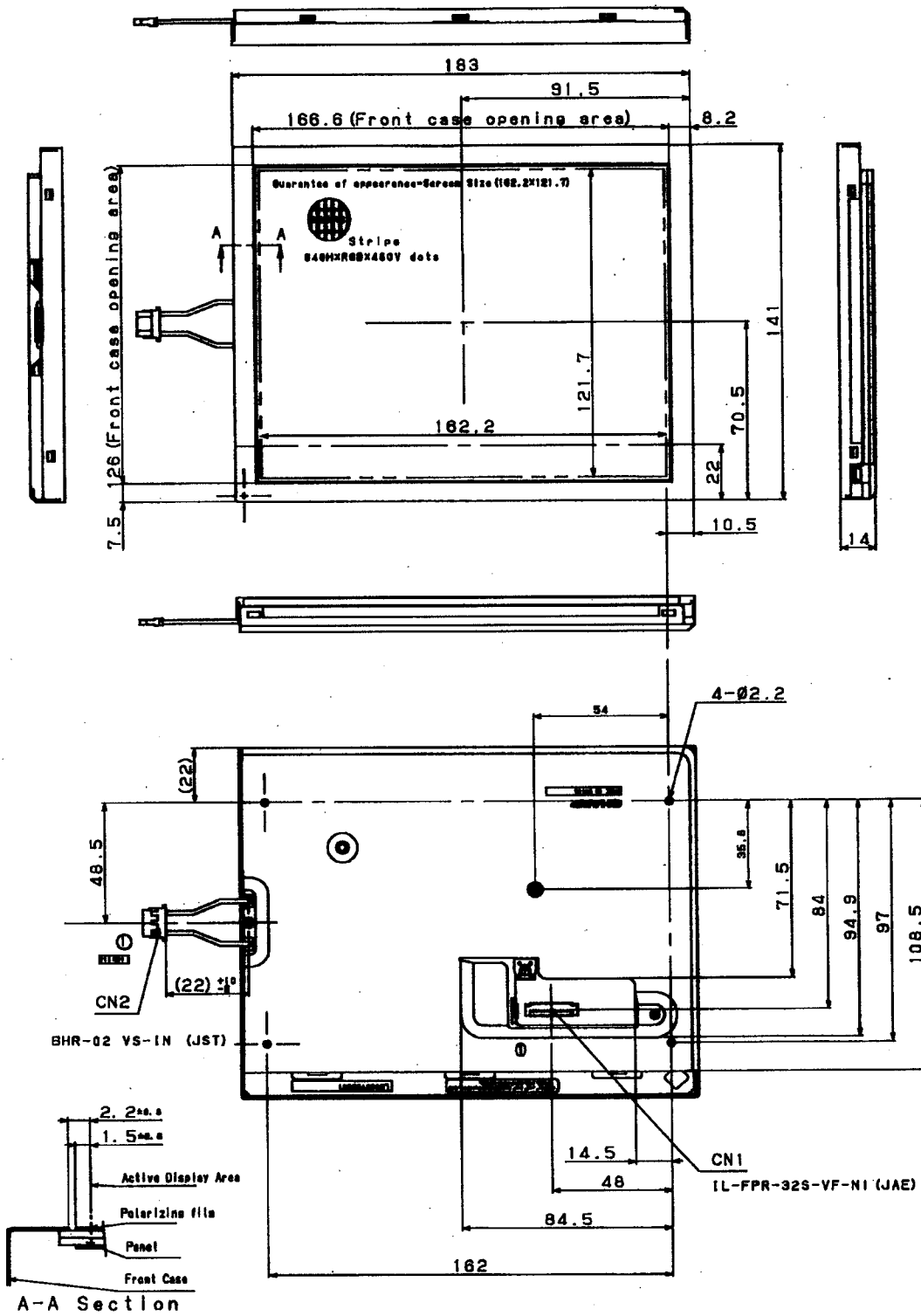

3 Take care in cut design to hide the scratches and bubbles occurred on the polarizer or other frame area which is located outside of active area.  
 2 Unit:mm  
 note 1) General tolerance ±0.5

Fig.1 Module dimension

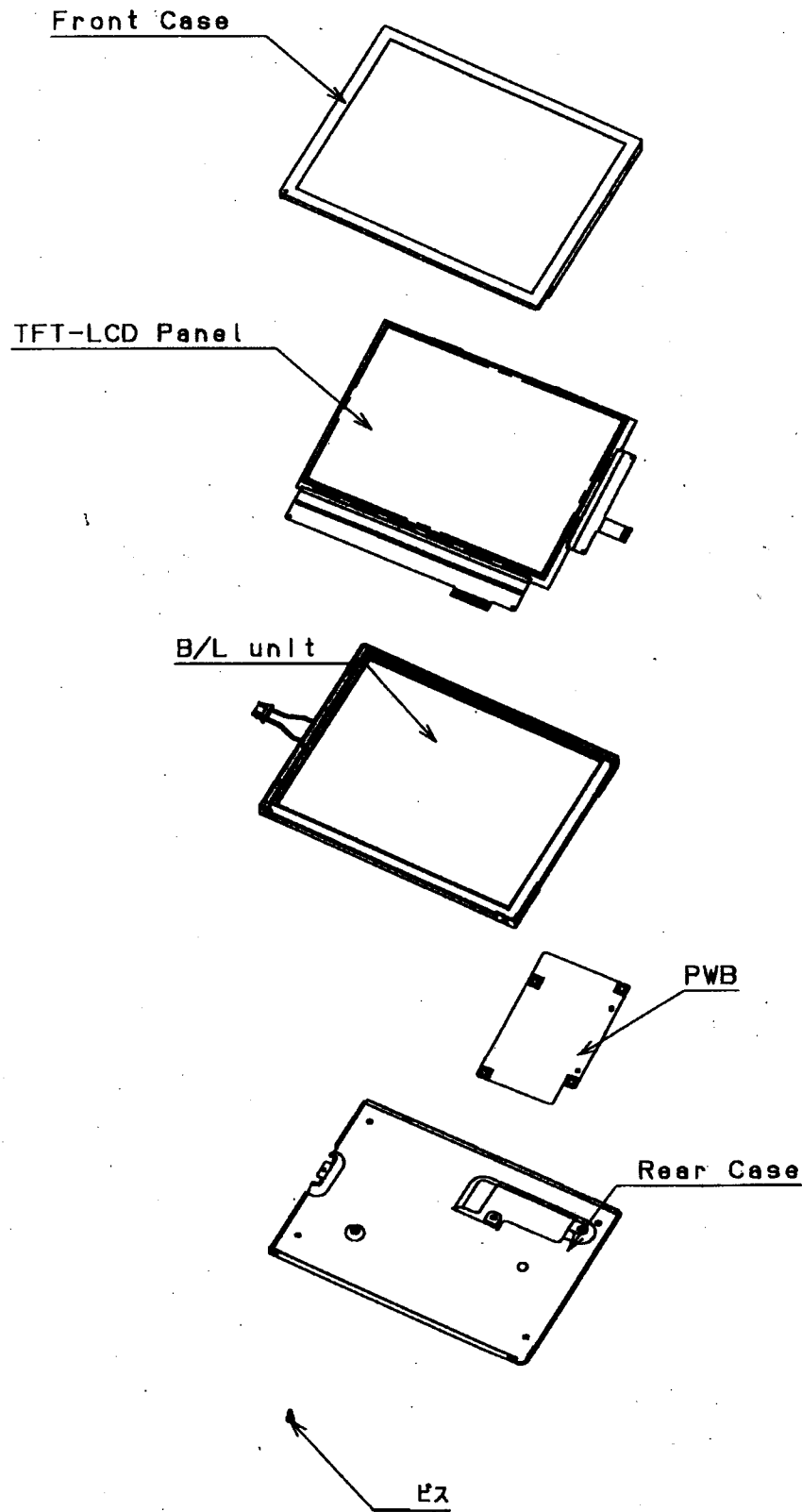

Fig.2 Assemble configuration

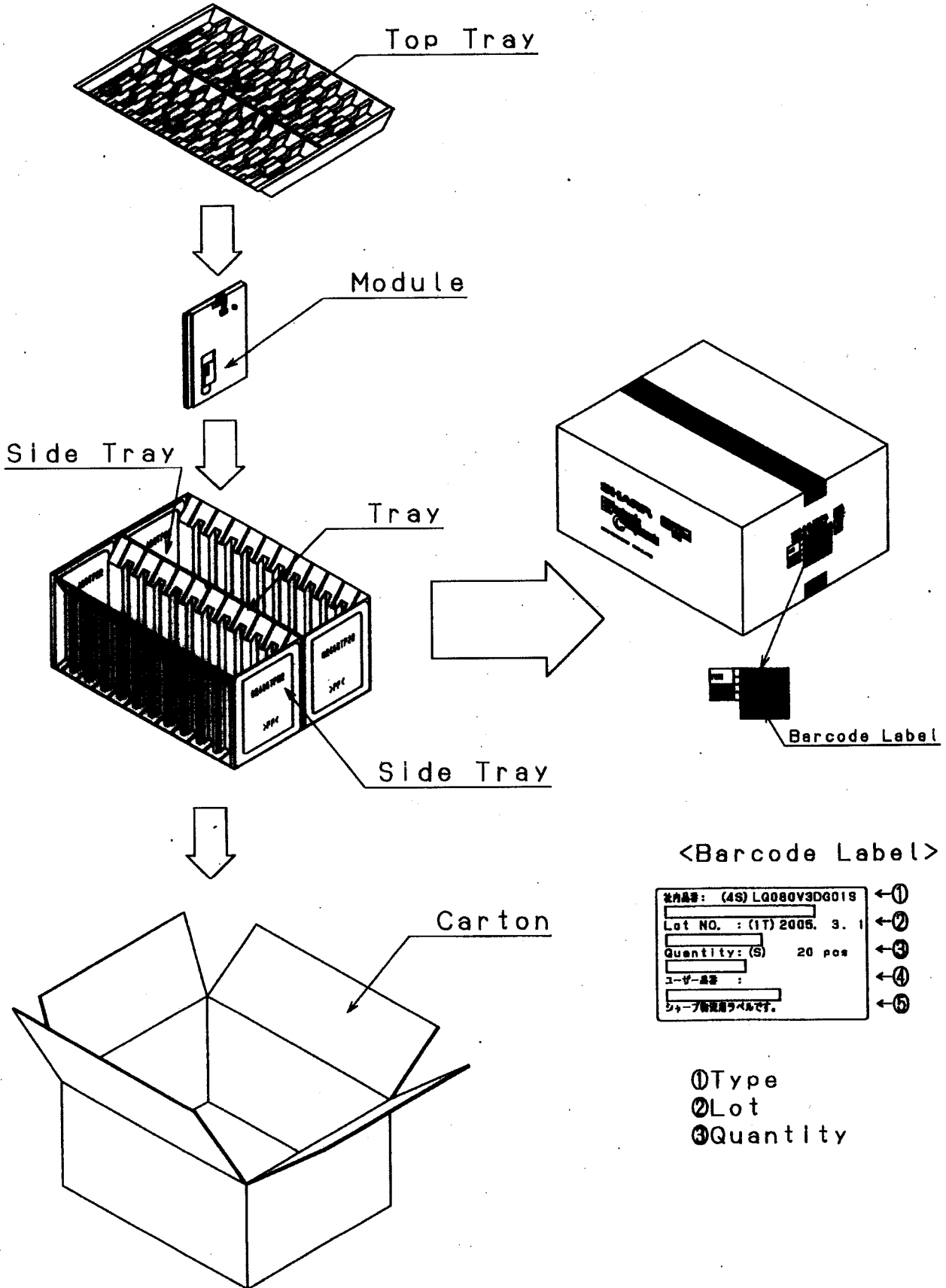

Fig.3 Packaging

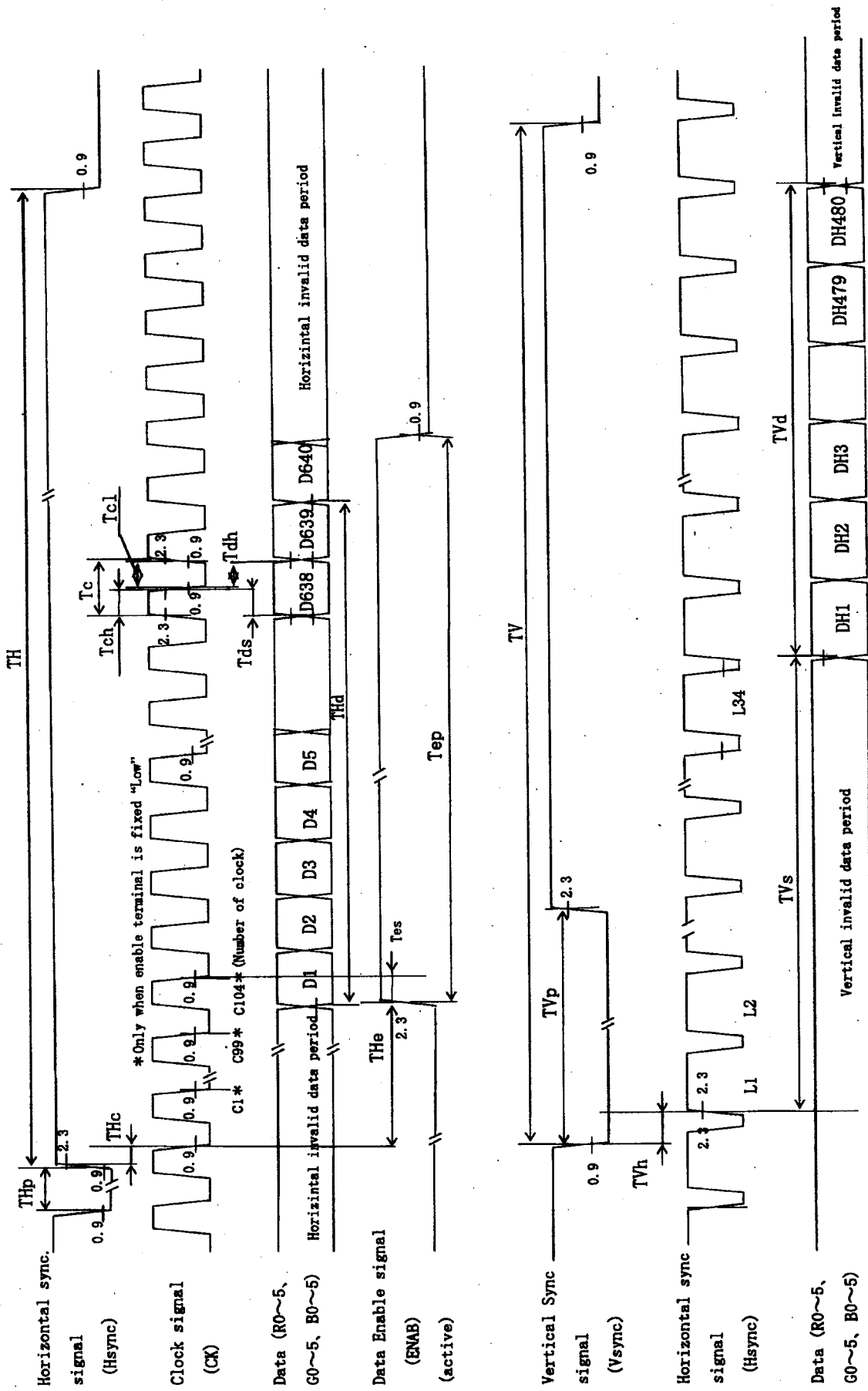

Fig 4. Input signal waveforms

**SPECIFICATIONS ARE SUBJECT TO CHANGE WITHOUT NOTICE.**

Suggested applications (if any) are for standard use; See Important Restrictions for limitations on special applications. See Limited Warranty for SHARP's product warranty. The Limited Warranty is in lieu, and exclusive of, all other warranties, express or implied. ALL EXPRESS AND IMPLIED WARRANTIES, INCLUDING THE WARRANTIES OF MERCHANTABILITY, FITNESS FOR USE AND FITNESS FOR A PARTICULAR PURPOSE, ARE SPECIFICALLY EXCLUDED. In no event will SHARP be liable, or in any way responsible, for any incidental or consequential economic or property damage.

---

# SHARP®

## **NORTH AMERICA**

---

SHARP Microelectronics of the Americas  
5700 NW Pacific Rim Blvd.  
Camas, WA 98607, U.S.A.  
Phone: (1) 360-834-2500  
Fax: (1) 360-834-8903  
Fast Info: (1) 800-833-9437  
www.sharpsma.com

## **EUROPE**

---

SHARP Microelectronics Europe  
Division of Sharp Electronics (Europe) GmbH  
Sonninstrasse 3  
20097 Hamburg, Germany  
Phone: (49) 40-2376-2286  
Fax: (49) 40-2376-2232  
www.sharpsme.com

## **JAPAN**

---

SHARP Corporation  
Electronic Components & Devices  
22-22 Nagaike-cho, Abeno-Ku  
Osaka 545-8522, Japan  
Phone: (81) 6-6621-1221  
Fax: (81) 6117-725300/6117-725301  
www.sharp-world.com

## **TAIWAN**

---

SHARP Electronic Components  
(Taiwan) Corporation  
8F-A, No. 16, Sec. 4, Nanking E. Rd.  
Taipei, Taiwan, Republic of China  
Phone: (886) 2-2577-7341  
Fax: (886) 2-2577-7326/2-2577-7328

## **SINGAPORE**

---

SHARP Electronics (Singapore) PTE., Ltd.  
438A, Alexandra Road, #05-01/02  
Alexandra Technopark,  
Singapore 119967  
Phone: (65) 271-3566  
Fax: (65) 271-3855

## **KOREA**

---

SHARP Electronic Components  
(Korea) Corporation  
RM 501 Geosung B/D, 541  
Dohwa-dong, Mapo-ku  
Seoul 121-701, Korea  
Phone: (82) 2-711-5813 ~ 8  
Fax: (82) 2-711-5819

## **CHINA**

---

SHARP Microelectronics of China  
(Shanghai) Co., Ltd.  
28 Xin Jin Qiao Road King Tower 16F  
Pudong Shanghai, 201206 P.R. China  
Phone: (86) 21-5854-7710/21-5834-6056  
Fax: (86) 21-5854-4340/21-5834-6057

### **Head Office:**

No. 360, Bashen Road,  
Xin Development Bldg. 22  
Waigaoqiao Free Trade Zone Shanghai  
200131 P.R. China  
Email: smc@china.global.sharp.co.jp

## **HONG KONG**

---

SHARP-ROXY (Hong Kong) Ltd.  
3rd Business Division,  
17/F, Admiralty Centre, Tower 1  
18 Harcourt Road, Hong Kong  
Phone: (852) 28229311  
Fax: (852) 28660779  
www.sharp.com.hk

### **Shenzhen Representative Office:**

Room 13B1, Tower C,  
Electronics Science & Technology Building  
Shen Nan Zhong Road  
Shenzhen, P.R. China  
Phone: (86) 755-3273731  
Fax: (86) 755-3273735