





**TFT LCD Approval Specification**

**MODEL NO.: N121X5 -L01**

Customer : \_\_\_\_\_

Approved by : \_\_\_\_\_

Note :

Liquid Crystal Display Division	
QRA Division.	OA Head Division.
Approval	Approval
	

- CONTENTS -

REVISION HISTORY	-----	3
1. GENERAL DESCRIPTION	-----	4
1.1 OVERVIEW		
1.2 FEATURES		
1.3 APPLICATION		
1.4 GENERAL SPECIFICATIONS		
1.5 MECHANICAL SPECIFICATIONS		
2. ABSOLUTE MAXIMUM RATINGS	-----	5
2.1 ABSOLUTE RATINGS OF ENVIRONMENT		
2.2 ELECTRICAL ABSOLUTE RATINGS		
2.2.1 TFT LCD MODULE		
2.2.2 BACKLIGHT UNIT		
3. ELECTRICAL CHARACTERISTICS	-----	7
3.1 TFT LCD MODULE		
3.2 BACKLIGHT UNIT		
4. BLOCK DIAGRAM	-----	13
4.1 TFT LCD MODULE		
4.2 BACKLIGHT UNIT		
5. INPUT TERMINAL PIN ASSIGNMENT	-----	14
5.1 TFT LCD MODULE		
5.2 BACKLIGHT UNIT		
5.3 TIMING DIAGRAM OF LVDS INPUT SIGNAL		
5.4 COLOR DATA INPUT ASSIGNMENT		
5.5 EDID DATA STRUCTURE		
5.6 EDID SIGNAL SPECIFICATION		
6. INTERFACE TIMING	-----	21
6.1 INPUT SIGNAL TIMING SPECIFICATIONS		
6.2 POWER ON/OFF SEQUENCE		
7. OPTICAL CHARACTERISTICS	-----	23
7.1 TEST CONDITIONS		
7.2 OPTICAL SPECIFICATIONS		
8. PRECAUTIONS	-----	27
8.1 HANDLING PRECAUTIONS		
8.2 STORAGE PRECAUTIONS		
8.3 OPERATION PRECAUTIONS		
9. PACKING	-----	28
9.1 CARTON		
9.2 PALLET		
10. DEFINITION OF LABELS	-----	30
10.1 CMO MODULE LABEL		
10.2 CARTON LABEL		

**REVISION HISTORY**

<b>Version</b>	<b>Date</b>	<b>Page (New)</b>	<b>Section</b>	<b>Description</b>
Ver 2.0	Apr. 14. '05	All	All	Approval specification first issued.
Ver 2.1	Jun. 06. '05	8	3.2	Modify the min value of Operating Frequency from 50 to 45 KHz
		16	5.5	Modify EDID DATA STRUCTURE
		23	7.2	Modify OPTICAL SPECIFICATIONS
Ver 2.2	Jul. 21. '05	16	5.5	Modify EDID DATA STRUCTURE
		23	7.1	Modify Inverter Driving Frequency
		31	Drawing	Modify outline drawing: the length of wire 60 → 79mm

## 1. GENERAL DESCRIPTION

### 1.1 OVERVIEW

N121X5 -L01 is a 12.1" TFT Liquid Crystal Display module with single CCFL Backlight unit and 20 pins LVDS interface. This module supports 1024 x 768 XGA mode and can display 262,144 colors. The optimum viewing angle is at 6 o'clock direction. The inverter module for Backlight is not built in.

### 1.2 FEATURES

- Thin and light weight
- XGA (1024 x 768 pixels) resolution
- DE (Data Enable) only mode
- 3.3V LVDS (Low Voltage Differential Signaling) interface with 1 pixel/clock
- Support EDID Structure Version 1 Revision 3

### 1.3 APPLICATION

- TFT LCD Notebook

### 1.4 GENERAL SPECIFICATIONS

Item	Specification	Unit	Note
Active Area	245.76 (H) X 184.32 (V)	mm	(1)
Bezel Opening Area	250.5 (H) x 188.9 (V)	mm	
Driver Element	a-si TFT active matrix	-	-
Pixel Number	1024 x R.G.B. x 768	pixel	-
Pixel Pitch	0.24 (H) x 0.24 (V)	mm	-
Pixel Arrangement	RGB vertical stripe	-	-
Display Colors	262,144	color	-
Transmissive Mode	Normally white	-	-
Surface Treatment	Hard coating (3H), Anti-glare (Haze 25 %)	-	-

### 1.5 MECHANICAL SPECIFICATIONS

Item	Min.	Typ.	Max.	Unit	Note	
Module Size	Horizontal(H)	260.5	261	261.5	mm	(1)
	Vertical(V)	197.5	198	198.5	mm	
	Depth(D)	--	4.7	5.0	mm	
Weight	--	260	275	g	-	

Note (1) Please refer to the attached drawings for more information of front and back outline dimensions.

Note (2) Connector mounting position

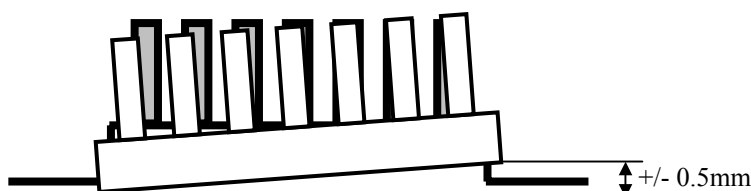

## 2. ABSOLUTE MAXIMUM RATINGS

### 2.1 ABSOLUTE RATINGS OF ENVIRONMENT

Item	Symbol	Value		Unit	Note
		Min.	Max.		
Storage Temperature	T <sub>ST</sub>	-20	+60	°C	(1)
Operating Ambient Temperature	T <sub>OP</sub>	0	+50	°C	(1), (2)
Shock (Non-Operating)	S <sub>NOP</sub>	-	220	G	(3), (5)
Vibration (Non-Operating)	V <sub>NOP</sub>	-	1.5	G	(4), (5)

Note (1) Temperature and relative humidity range is shown in the figure below.

- (a) 90 %RH Max. ( $T_a \leq 40\text{ }^\circ\text{C}$ ).
- (b) Wet-bulb temperature should be 39 °C Max. ( $T_a > 40\text{ }^\circ\text{C}$ ).
- (c) No condensation .

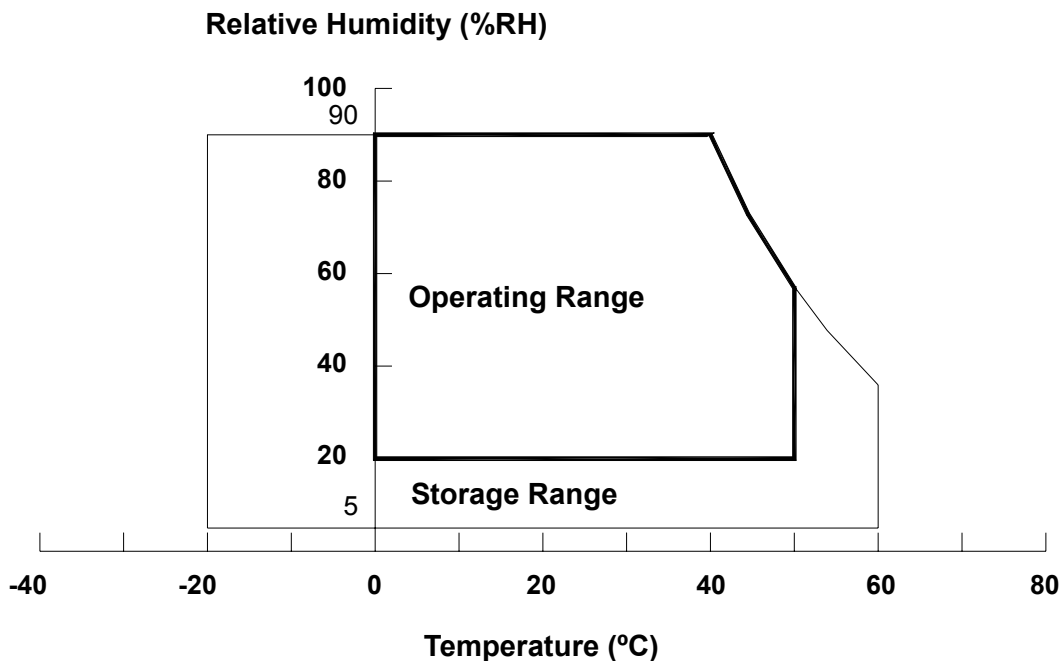

Note (2) The temperature of panel surface should be 0 °C Min. and 50 °C Max.

Note (3) 2ms, half sine wave, 1 time for ± X, ± Y, ± Z.

Note (4) 10 ~ 200 Hz, 0.5 Hr / Cycle, 1 cycles for each X, Y, Z. The fixing condition is shown as below:

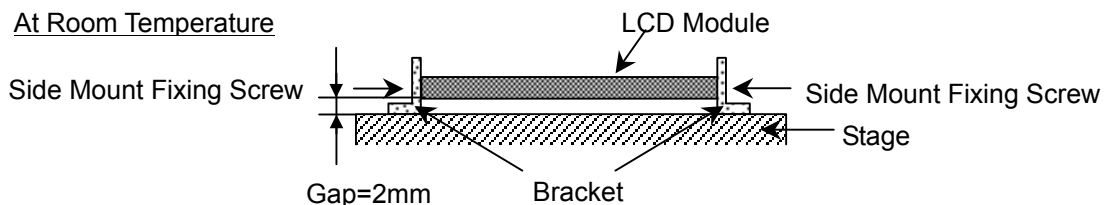

Note (5) At testing Vibration and Shock, the fixture in holding the module has to be hard and rigid enough so that the module would not be twisted or bent by the fixture.

## 2.2 ELECTRICAL ABSOLUTE RATINGS

### 2.2.1 TFT LCD MODULE

Item	Symbol	Value		Unit	Note
		Min.	Max.		
Power Supply Voltage	V <sub>CC</sub>	-0.3	+4.0	V	(1)
Logic Input Voltage	V <sub>IN</sub>	-0.3	V <sub>CC</sub> +0.3	V	

### 2.2.2 BACKLIGHT UNIT

Item	Symbol	Value		Unit	Note
		Min.	Max.		
Lamp Voltage	V <sub>L</sub>	-	2.5K	V <sub>RMS</sub>	(1), (2), I <sub>L</sub> = (6.0) mA
Lamp Current	I <sub>L</sub>	-	6.5	mA <sub>RMS</sub>	
Lamp Frequency	F <sub>L</sub>	-	80	KHz	(1), (2)

Note (1) Permanent damage to the device may occur if maximum values are exceeded. Function operation should be restricted to the conditions described under Normal Operating Conditions.

Note (2) Specified values are for lamp (Refer to Section 3.2 for further information).

### 3. ELECTRICAL CHARACTERISTICS

#### 3.1 TFT LCD MODULE

Ta = 25 ± 2 °C

Parameter	Symbol	Value			Unit	Note
		Min.	Typ.	Max.		
Power Supply Voltage	V <sub>CC</sub>	3.0	3.3	3.6	V	-
Ripple Voltage	V <sub>RP</sub>	-	-	100	mV	-
Rush Current	I <sub>RUSH</sub>	-	-	1.5	A	(2)
Power Supply Current	White	-	230	270	mA	(3)a
	Black	-	280	330	mA	(3)b
Differential Input Voltage for LVDS Receiver Threshold	"H" Level	-	-	+100	mV	-
	"L" Level	-100	-	-	mV	-
Terminating Resistor	R <sub>T</sub>	-	100	-	Ohm	-

Note (1) The module should be always operated within above ranges.

Note (2) Measurement Conditions:

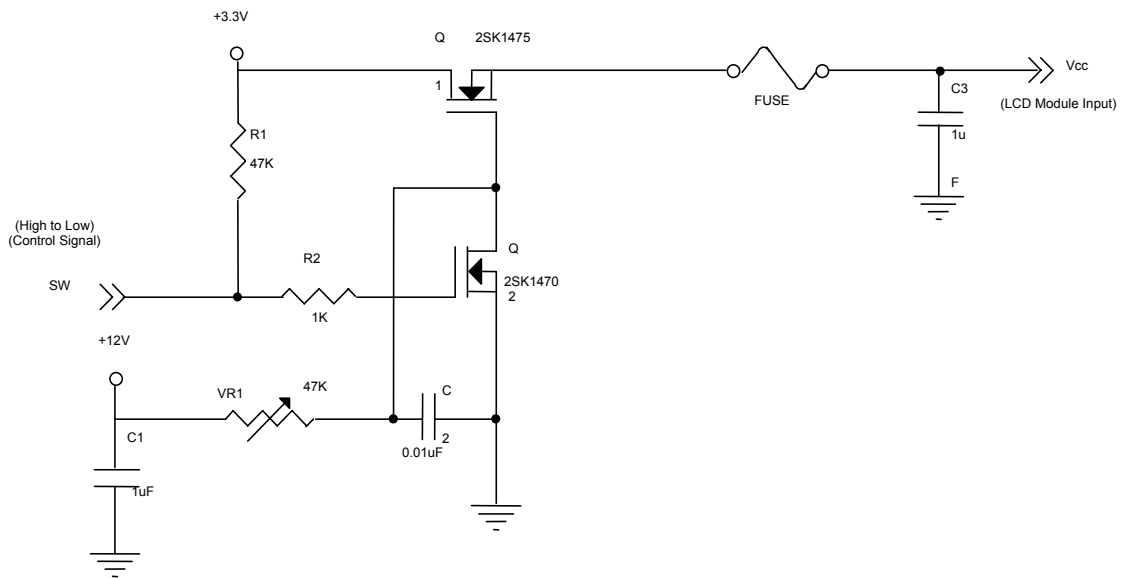

**Vcc rising time is 470us**

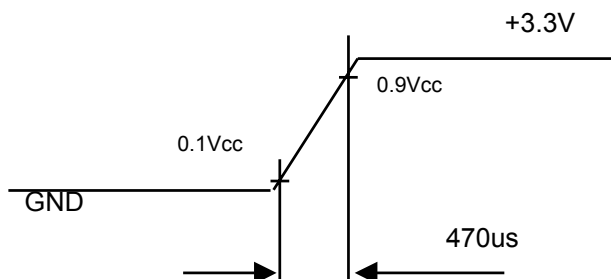

Note (3) The specified power supply current is under the conditions at  $V_{CC} = 3.3 \text{ V}$ ,  $T_a = 25 \pm 2 \text{ }^\circ\text{C}$ , DC Current and  $f_v = 60 \text{ Hz}$ , whereas a power dissipation check pattern below is displayed.

a. White Pattern

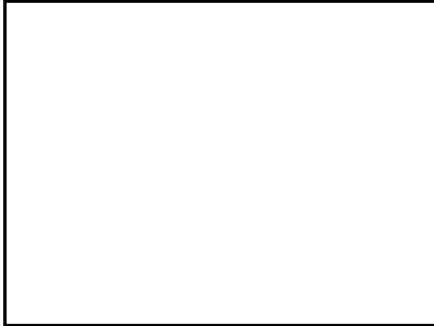

Active Area

b. Black Pattern

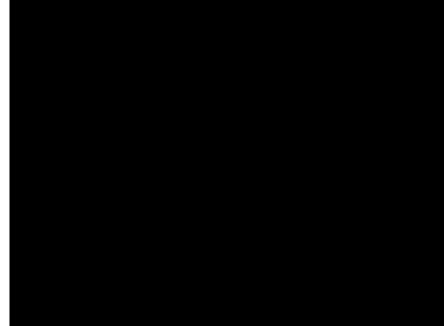

Active Area

### 3.2 BACKLIGHT UNIT

 $T_a = 25 \pm 2 \text{ }^\circ\text{C}$ 

Parameter	Symbol	Value			Unit	Note
		Min.	Typ.	Max.		
Lamp Input Voltage	$V_L$	540	600	660	$V_{RMS}$	$I_L = 5.0 \text{ mA}$
Lamp Current	$I_L$	3.0	5.0	6.0	$\text{mA}_{RMS}$	(1),(7)
Lamp Turn On Voltage	$V_S$	-	-	1170 (25 $^\circ\text{C}$ )	$V_{RMS}$	(2)
		-	-	1340 (0 $^\circ\text{C}$ )	$V_{RMS}$	(2)
Operating Frequency	$F_L$	45	-	80	KHz	(3)
Power Consumption	$P_L$	-	3.0	-	W	(4), $I_L = 5.0 \text{ mA}$
Lamp Life Time	$L_{BL}$	10,000	-	-	Hrs	(5)

Note (1) Lamp current is measured by utilizing a high frequency current meter as shown below:

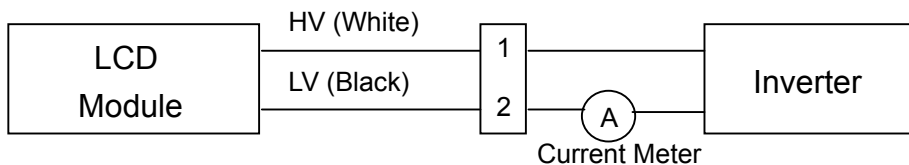

Note (2) The voltage shown above should be applied to the lamp for more than 1 second after startup. Otherwise the lamp may not be turned on.



Note (3) The lamp frequency may generate interference with horizontal synchronous frequency from the display, and this may cause line flow on the display. In order to avoid interference, the lamp frequency should be detached from the horizontal synchronous frequency and its harmonics as far as possible.

Note (4)  $P_L = I_L \times V_L$

Note (5) The lifetime of lamp is defined as the time when it continues to operate under the conditions at  $T_a = 25 \pm 2 \text{ }^\circ\text{C}$  and  $I_L = 6.0\text{mA}_{\text{RMS}}$  until one of the following events occurs:

(a) When the brightness becomes  $\leq 50\%$  of its original value.

(b) When the effective ignition length becomes  $\leq 80\%$  of its original value. (Effective ignition length is defined as an area that the brightness is less than 70% compared to the center point.)

Note (6) The waveform of the voltage output of inverter must be area-symmetric and the design of the inverter must have specifications for the modularized lamp. The performance of the Backlight, such as lifetime or brightness, is greatly influenced by the characteristics of the DC-AC inverter for the lamp. All the parameters of an inverter should be carefully designed to avoid generating too much current leakage from high voltage output of the inverter. When designing or ordering the inverter please make sure that a poor lighting caused by the mismatch of the Backlight and the inverter (miss-lighting, flicker, etc.) never occurs. If the above situation is confirmed, the module should be operated in the same manners when it is installed in your instrument.

The output of the inverter must have symmetrical (negative and positive) voltage waveform and symmetrical current waveform. (Unsymmetrical ratio is less than 10%) Please do not use the inverter, which has unsymmetrical voltage and unsymmetrical current and spike wave. Lamp frequency may produce interface with horizontal synchronous frequency and as a result this may cause beat on the display. Therefore lamp frequency shall be as away possible from the horizontal synchronous frequency and from its harmonics in order to prevent interference.

Requirements for a system inverter design, which is intended to have a better display performance, a better power efficiency and a more reliable lamp. It shall help increase the lamp lifetime and reduce its leakage current.

- a. The asymmetry rate of the inverter waveform should be 10% below;
- b. The distortion rate of the waveform should be within  $\sqrt{2} \pm 10\%$ ;
- c. The ideal sine wave form shall be symmetric in positive and negative polarities.

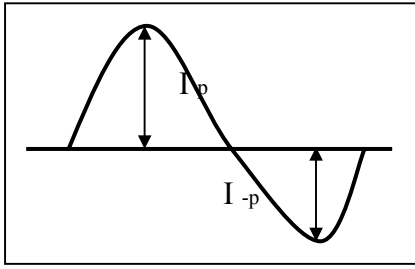

\* Asymmetry rate:  

$$| I_p - I_{-p} | / I_{rms} * 100\%$$

\* Distortion rate  

$$I_p \text{ (or } I_{-p}) / I_{rms}$$

Note (7) The lamp leakage current is measured by the current difference between in and out. And the measurement condition is as below:

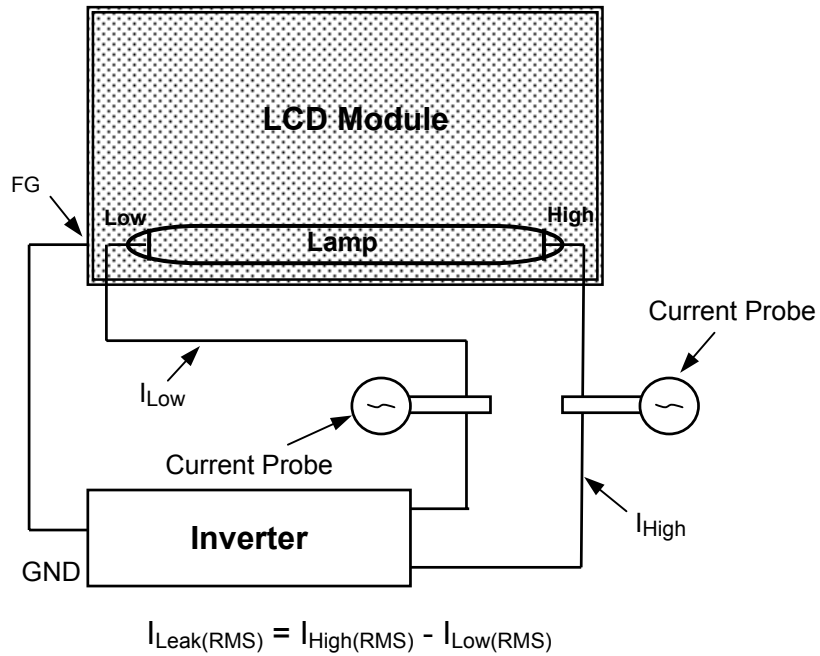

Note (8) About operating current min 2.0mA , lamp maker has some advice as below

(Reference) Light quantity adjustment method

Explanation and comparison of the kind of tone light:

- ① Lamp current wave-like by the adjustment of the current.

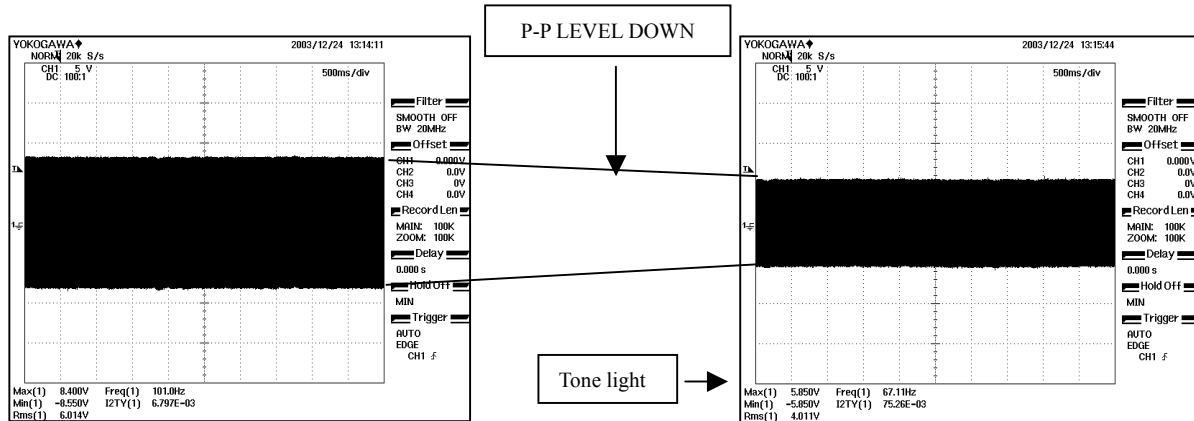

- ② Lamp current wave-like by the adjustment of the burst.

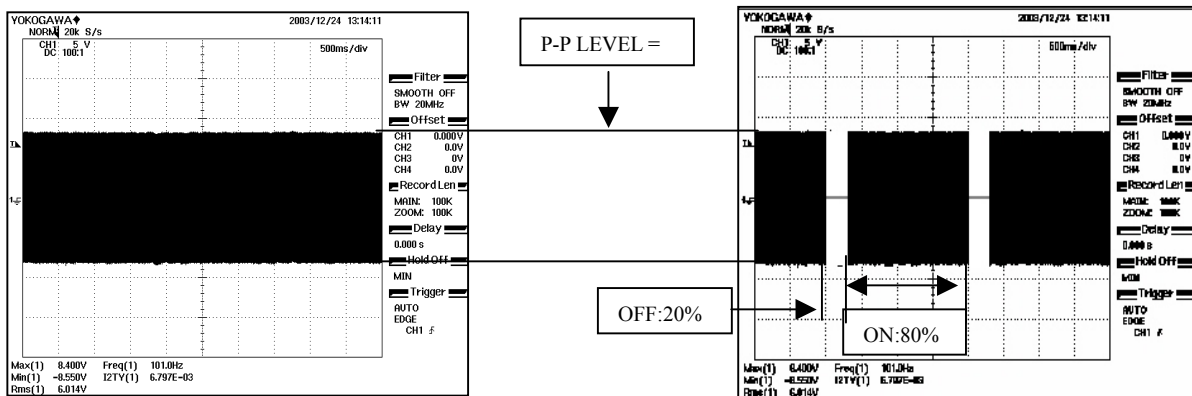

Comparative table

Method	Backlight efficiency (INV+LAMP)	Tone light rate (%)	Circuitry
①current	Good ( 75 % ~ 85% )	58	Complicated
②burst	Bad ( 65 % ~ 75% )	10	Easy

Method of case that Lamp current MIN2.0mA is controlled.

It is the setting of minimum 2.0mA (MIN) to Lamp current 6.0mA in the lamp specification. The burst is excellent for circuitry. The marker proposes that pays attention to the following contents.

The attention point of the light with a touch of the burst:

- ① Do not to be SPARK at start.

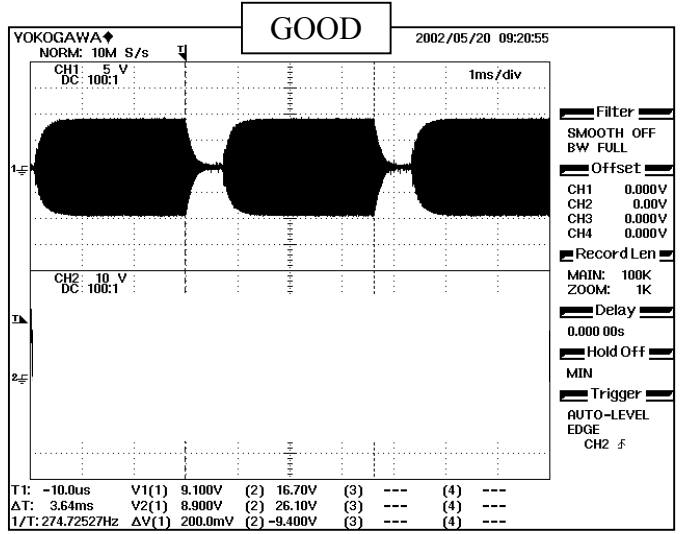
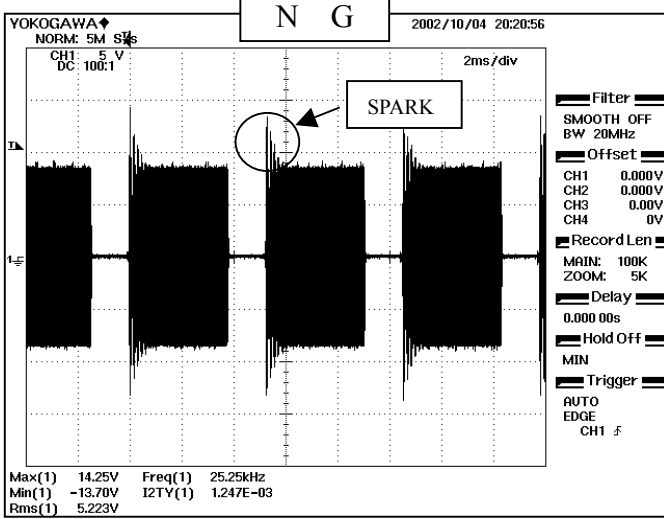

- ② PWM frequency does so that the frequency that is not able to divide the fixed number time, fixed number to lamp drive frequency is selected. (It is due to resonance noise occurrence prevention. )  
 Even the frequency that is using it for LCD avoids selecting it.

## 4. BLOCK DIAGRAM

### 4.1 TFT LCD MODULE

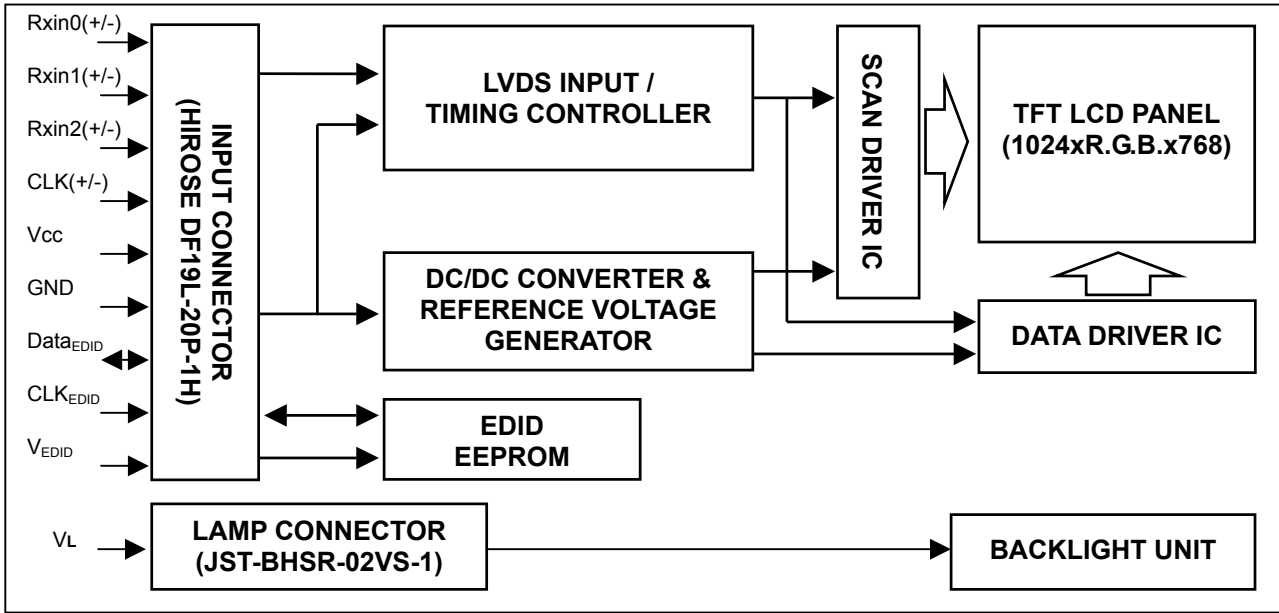

### 4.2 BACKLIGHT UNIT

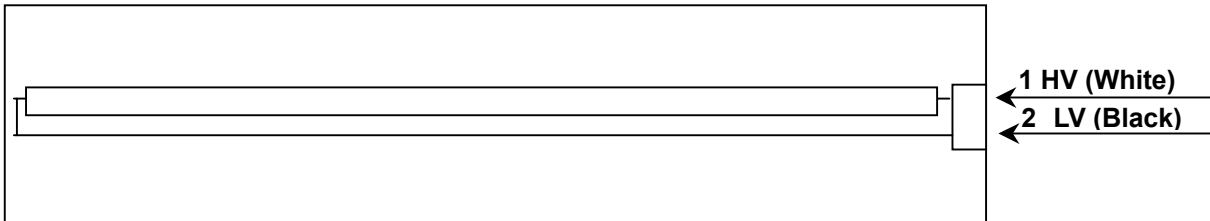

## 5. INPUT TERMINAL PIN ASSIGNMENT

### 5.1 TFT LCD MODULE

Pin	Symbol	Description	Polarity	Remark
1	Vss	Ground		
2	Vcc	Power Supply +3.3 V (typical)		
3	Vcc	Power Supply +3.3 V (typical)		
4	V <sub>EDID</sub>	DDC 3.3V Power		DDC 3.3V Power
5	NC	Non-Connection		
6	CLK <sub>EDID</sub>	DDC Clock		DDC Clock
7	DATA <sub>EDID</sub>	DDC Data		DDC Data
8	Rxin0-	LVDS Differential Data Input	Negative	R0~R5,G0
9	Rxin0+	LVDS Differential Data Input	Positive	
10	Vss	Ground		G1~G5,B0,B1
11	Rxin1-	LVDS Differential Data Input	Negative	
12	Rxin1+	LVDS Differential Data Input	Positive	-
13	Vss	Ground		B2~B5,DE,Hsync,Vsync
14	Rxin2-	LVDS Differential Data Input	Negative	
15	Rxin2+	LVDS Differential Data Input	Positive	
16	Vss	Ground		LVDS Level Clock
17	CLK-	LVDS Clock Data Input	Negative	
18	CLK+	LVDS Clock Data Input	Positive	
19	Vss	Ground		
20	Vss	Ground		

Note (1) The first pixel is even.

Note (2) Connector Part No.: HIROSE DF19L-20P-1H or equivalent

Note (3) User's connector Part No: HIROSE DF19G-20S-1C or equivalent

### 5.2 BACKLIGHT UNIT

Pin	Symbol	Description	Color
1	HV	High Voltage	White
2	LV	Ground	Black

Note (1) Connector Part No.: JST-BHSR-02VS-1 or equivalent

Note (2) User's connector Part No.: JST-SM02B-BHSS-1-TB or equivalent

### 5.3 TIMING DIAGRAM OF LVDS INPUT SIGNAL

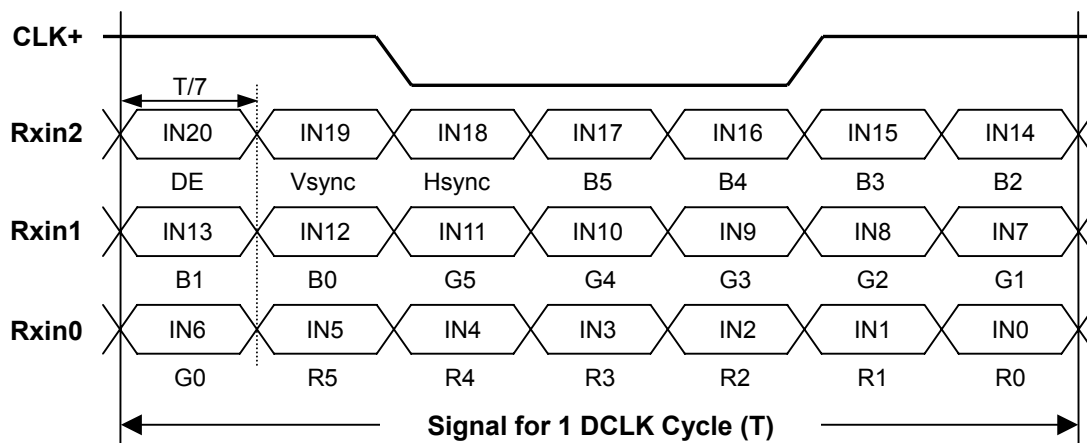

5.4 COLOR DATA INPUT ASSIGNMENT

The brightness of each primary color (red, green and blue) is based on the 6-bit gray scale data input for the color. The higher the binary input the brighter the color. The table below provides the assignment of color versus data input.

Color		Data Signal																	
		Red						Green						Blue					
		R5	R4	R3	R2	R1	R0	G5	G4	G3	G2	G1	G0	B5	B4	B3	B2	B1	B0
Basic Colors	Black	0	0	0	0	0	0	0	0	0	0	0	0	0	0	0	0	0	0
	Red	1	1	1	1	1	1	0	0	0	0	0	0	0	0	0	0	0	0
	Green	0	0	0	0	0	0	1	1	1	1	1	1	0	0	0	0	0	0
	Blue	0	0	0	0	0	0	0	0	0	0	0	0	1	1	1	1	1	1
	Cyan	0	0	0	0	0	0	1	1	1	1	1	1	1	1	1	1	1	1
	Magenta	1	1	1	1	1	1	0	0	0	0	0	0	0	1	1	1	1	1
	Yellow	1	1	1	1	1	1	1	1	1	1	1	1	0	0	0	0	0	0
	White	1	1	1	1	1	1	1	1	1	1	1	1	1	1	1	1	1	1
Gray Scale Of Red	Red(0)/Dark	0	0	0	0	0	0	0	0	0	0	0	0	0	0	0	0	0	0
	Red(1)	0	0	0	0	0	1	0	0	0	0	0	0	0	0	0	0	0	0
	Red(2)	0	0	0	0	1	0	0	0	0	0	0	0	0	0	0	0	0	0
	:	:	:	:	:	:	:	:	:	:	:	:	:	:	:	:	:	:	:
	:	:	:	:	:	:	:	:	:	:	:	:	:	:	:	:	:	:	:
	:	:	:	:	:	:	:	:	:	:	:	:	:	:	:	:	:	:	:
	Red(61)	1	1	1	1	0	1	0	0	0	0	0	0	0	0	0	0	0	0
	Red(62)	1	1	1	1	1	0	0	0	0	0	0	0	0	0	0	0	0	0
Red(63)	1	1	1	1	1	1	0	0	0	0	0	0	0	0	0	0	0	0	
Gray Scale Of Green	Green(0)/Dark	0	0	0	0	0	0	0	0	0	0	0	0	0	0	0	0	0	0
	Green(1)	0	0	0	0	0	0	0	0	0	0	0	1	0	0	0	0	0	0
	Green(2)	0	0	0	0	0	0	0	0	0	0	1	0	0	0	0	0	0	0
	:	:	:	:	:	:	:	:	:	:	:	:	:	:	:	:	:	:	:
	:	:	:	:	:	:	:	:	:	:	:	:	:	:	:	:	:	:	:
	:	:	:	:	:	:	:	:	:	:	:	:	:	:	:	:	:	:	:
	Green(61)	0	0	0	0	0	0	1	1	1	1	0	1	0	0	0	0	0	0
	Green(62)	0	0	0	0	0	0	1	1	1	1	1	0	0	0	0	0	0	0
Green(63)	0	0	0	0	0	0	1	1	1	1	1	1	0	0	0	0	0	0	
Gray Scale Of Blue	Blue(0)/Dark	0	0	0	0	0	0	0	0	0	0	0	0	0	0	0	0	0	0
	Blue(1)	0	0	0	0	0	0	0	0	0	0	0	0	0	0	0	0	0	1
	Blue(2)	0	0	0	0	0	0	0	0	0	0	0	0	0	0	0	0	1	0
	:	:	:	:	:	:	:	:	:	:	:	:	:	:	:	:	:	:	:
	:	:	:	:	:	:	:	:	:	:	:	:	:	:	:	:	:	:	:
	:	:	:	:	:	:	:	:	:	:	:	:	:	:	:	:	:	:	:
	Blue(61)	0	0	0	0	0	0	0	0	0	0	0	0	1	1	1	1	0	1
	Blue(62)	0	0	0	0	0	0	0	0	0	0	0	0	1	1	1	1	1	0
Blue(63)	0	0	0	0	0	0	0	0	0	0	0	0	1	1	1	1	1	1	

Note (1) 0: Low Level Voltage, 1: High Level Voltage

## 5.5 EDID DATA STRUCTURE

The EDID (Extended Display Identification Data) data formats are to support displays as defined in the VESA Plug & Display and FPD standards.

Byte # (decimal)	Byte # (hex)	Field Name and Comments	Value (hex)	Value (binary)
0	0	Header	00	00000000
1	1	Header	FF	11111111
2	2	Header	FF	11111111
3	3	Header	FF	11111111
4	4	Header	FF	11111111
5	5	Header	FF	11111111
6	6	Header	FF	11111111
7	7	Header	00	00000000
8	8	EISA ID manufacturer name ( "CMO" )	0D	00001101
9	9	EISA ID manufacturer name (Compressed ASCII)	AF	10101111
10	0A	ID product code (N121X5-L01)	04	00000100
11	0B	ID product code (hex LSB first; N121X5-L01)	12	00010010
12	0C	ID S/N (fixed "0" )	00	00000000
13	0D	ID S/N (fixed "0" )	00	00000000
14	0E	ID S/N (fixed "0" )	00	00000000
15	0F	ID S/N (fixed "0" )	00	00000000
16	10	Week of manufacture (fixed "17" )	11	00010001
17	11	Year of manufacture (fixed "2005" )	0F	00001111
18	12	EDID structure version # ( "1" )	01	00000001
19	13	EDID revision # ( "3" )	03	00000011
20	14	Video I/P definition ( "digital" )	80	10000000
21	15	Max H image size ( "24.576 cm" )	19	00011001
22	16	Max V image size ( "18.432 cm" )	12	00010010
23	17	Display Gamma (Gamma = " 2.2" )	78	01111000
24	18	Feature support ( "RGB, preferred timing" )	0A	00001010
25	19	Red/Green (Rx1, Rx0, Ry1, Ry0, Gx1, Gx0, Gy1, Gy0)	FE	11111110
26	1A	Blue/White (Bx1, Bx0, By1, By0, Wx1, Wx0, Wy1, Wy0)	65	01100101
27	1B	Red-x (Rx = "0.585")	95	10010101
28	1C	Red-y (Ry = "0.335")	55	01010101
29	1D	Green-x (Gx = "0.32")	51	01010001
30	1E	Green-y (Gy = "0.53")	87	10000111
31	1F	Blue-x (Bx = "0.15")	26	00100110
32	20	Blue-y (By = "0.135")	22	00100010
33	21	White-x (Wx = "0.313")	50	01010000
34	22	White-y (Wy = "0.329")	54	01010100
35	23	Established timings 1	00	00000000
36	24	Established timings 2 (1024x768@60Hz)	08	00001000
37	25	Manufacturer's reserved timings	00	00000000
38	26	Standard timing ID # 1	01	00000001
39	27	Standard timing ID # 1	01	00000001
40	28	Standard timing ID # 2	01	00000001
41	29	Standard timing ID # 2	01	00000001



Byte # (decimal)	Byte # (hex)	Field Name and Comments	Value (hex)	Value (binary)
42	2A	Standard timing ID # 3	01	00000001
43	2B	Standard timing ID # 3	01	00000001
44	2C	Standard timing ID # 4	01	00000001
45	2D	Standard timing ID # 4	01	00000001
46	2E	Standard timing ID # 5	01	00000001
47	2F	Standard timing ID # 5	01	00000001
48	30	Standard timing ID # 6	01	00000001
49	31	Standard timing ID # 6	01	00000001
50	32	Standard timing ID # 7	01	00000001
51	33	Standard timing ID # 7	01	00000001
52	34	Standard timing ID # 8	01	00000001
53	35	Standard timing ID # 8	01	00000001
54	36	Detailed timing description # 1 Pixel clock ( "65 MHz" )	64	01100100
55	37	# 1 Pixel clock (hex LSB first)	19	00011001
56	38	# 1 H active ( "1024" )	00	00000000
57	39	# 1 H blank ( "320" )	40	01000000
58	3A	# 1 H active: H blank ( "1024 : 320" )	41	01000001
59	3B	# 1 V active ( " 768" )	00	00000000
60	3C	# 1 V blank ( " 38" )	26	00100110
61	3D	# 1 V active: V blank ( " 768 : 38" )	30	00110000
62	3E	# 1 H sync offset ( " 24" )	18	00011000
63	3F	# 1 H sync pulse width ( " 136" )	88	10001000
64	40	# 1 V sync offset: V sync pulse width ( " 3 : 6" )	36	00110110
65	41	# 1 H sync offset: H sync pulse width : V sync offset : V sync width ( " 24 : 136 : 3 : 6" )	00	00000000
66	42	# 1 H image size ( " 245.76 mm" )	F6	11110110
67	43	# 1 V image size ( " 184.32 mm" )	B8	10111000
68	44	# 1 H image size: V image size ( " 245 : 184" )	00	00000000
69	45	# 1 H boarder ( " 0" )	00	00000000
70	46	# 1 V boarder ( " 0" )	00	00000000
71	47	# 1 Flags ( " Non-Interlace, Non-Stereo, Digital Separate" )	18	00011000
72	48	Detailed timing description # 2	00	00000000
73	49	# 2 Flag	00	00000000
74	4A	# 2 Reserved	00	00000000
75	4B	# 2 FE (hex) defines ASCII string (Model Name "N121X5" , ASCII)	FE	11111110
76	4C	# 2 Flag	00	00000000
77	4D	# 2 1st character of string ( "N" )	4E	01001110
78	4E	# 2 2nd character of string ( "1" )	31	00110001
79	4F	# 2 3rd character of string ( "2" )	32	00110010
80	50	# 2 4th character of string ( "1" )	31	00110001
81	51	# 2 5th character of string ( "X" )	58	01011000
82	52	# 2 6th character of string ( "5" )	35	00110101
83	53	# 2 7th character of string ( "-" )	2D	00101101
84	54	# 2 8th character of string ( "L" )	4C	01001100
85	55	# 2 9th character of string ( "0" )	30	00110000

Byte # (decimal)	Byte # (hex)	Field Name and Comments	Value (hex)	Value (binary)
86	56	# 2 10th character of string ( "1" )	31	00110001
87	57	# 2 New line character # 2 indicates end of ASCII string	0A	00001010
88	58	# 2 Padding with "Blank" character	20	00100000
89	59	# 2 Padding with "Blank" character	20	00100000
90	5A	Detailed timing description # 3	00	00000000
91	5B	# 3 Flag	00	00000000
92	5C	# 3 Reserved	00	00000000
93	5D	# 3 FE (hex) defines ASCII string (Vendor "CMO" , ASCII)	FE	11111110
94	5E	# 3 Flag	00	00000000
95	5F	# 3 1st character of string ( "C" )	43	01000011
96	60	# 3 2nd character of string ( "M" )	4D	01001101
97	61	# 3 3rd character of string ( "O" )	4F	01001111
98	62	# 3 New line character # 3 indicates end of ASCII string	0A	00001010
99	63	# 3 Padding with "Blank" character	20	00100000
100	64	# 3 Padding with "Blank" character	20	00100000
101	65	# 3 Padding with "Blank" character	20	00100000
102	66	# 3 Padding with "Blank" character	20	00100000
103	67	# 3 Padding with "Blank" character	20	00100000
104	68	# 3 Padding with "Blank" character	20	00100000
105	69	# 3 Padding with "Blank" character	20	00100000
106	6A	# 3 Padding with "Blank" character	20	00100000
107	6B	# 3 Padding with "Blank" character	20	00100000
108	6C	Detailed timing description # 4	00	00000000
109	6D	# 4 Flag	00	00000000
110	6E	# 4 Reserved	00	00000000
111	6F	# 4 FE (hex) defines ASCII string (Model Name "N121X5-L01" , ASCII)	FE	11111110
112	70	# 4 Flag	00	00000000
113	71	# 4 1st character of name ( "N" )	4E	01001110
114	72	# 4 2nd character of name ( "1" )	31	00110001
115	73	# 4 3rd character of name ( "2" )	32	00110010
116	74	# 4 4th character of name ( "1" )	31	00110001
117	75	# 4 5th character of name ( "X" )	58	01011000
118	76	# 4 6th character of name ( "5" )	35	00110101
119	77	# 4 7th character of name ( "-" )	2D	00101101
120	78	# 4 8th character of name ( "L" )	4C	01001100
121	79	# 4 9th character of name ( "0" )	30	00110000
122	7A	# 4 10th character of name ( "1" )	31	00110001
123	7B	# 4 New line character # 4 indicates end of Monitor name	0A	00001010
124	7C	# 4 Padding with "Blank" character	20	00100000
125	7D	# 4 Padding with "Blank" character	20	00100000
126	7E	Extension flag	00	00000000
127	7F	Checksum	A1	10100001

### 5.6 EDID SIGNAL SPECIFICATION

#### (1) EDID Power

Parameter	Symbol	Conditions	Min.	Typ.	Max.	Unit
Power supply voltage	V <sub>CC</sub>	Read Operation	2.2	—	5.5	V

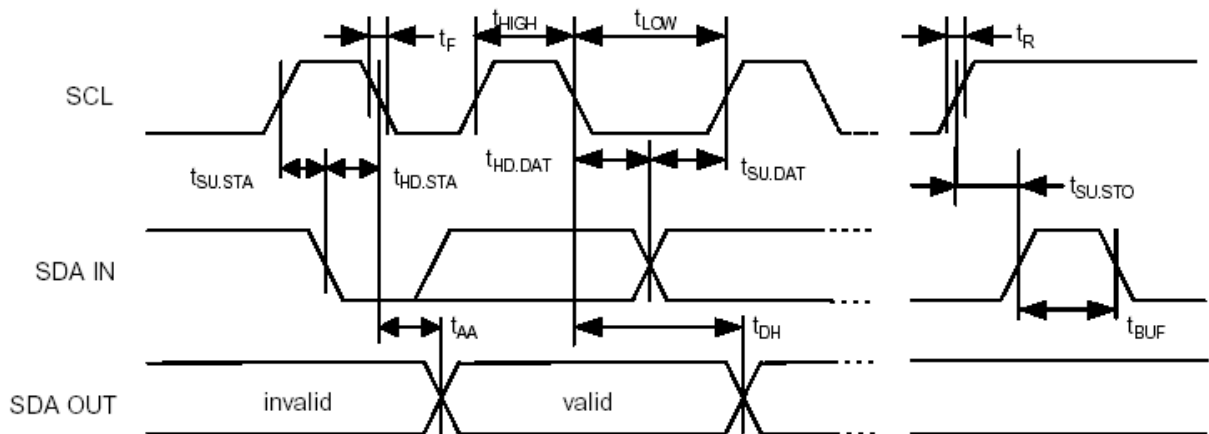

#### (2) DC characteristics

		Symbol	Min.	Max.	Unit	Index
SCL, SDA terminal input voltage	High Voltage	V <sub>IH</sub>	0.7 V <sub>CC</sub>	—	V	
	Low Voltage	V <sub>IL</sub>	—	0.3 V <sub>CC</sub>	V	
Hysteresis Voltage		V <sub>HYS</sub>	0.05 V <sub>CC</sub>	—	V	
Output Voltage		V <sub>OL1</sub> V <sub>OL2</sub>	—	0.4 0.6	V	I <sub>OL</sub> =3mA, CC=2.5V I <sub>OL</sub> =6mA, CC=2.5V
Input Leak current (V <sub>in</sub> =0.1V~V <sub>CC</sub> )		I <sub>LI</sub>	-10 -10	10 50	uA	WP=V <sub>SS</sub> WP=V <sub>CC</sub>
Output Leak current		I <sub>LO</sub>	-10	10	uA	V <sub>out</sub> =0.1V~V <sub>CC</sub> , WP=V <sub>SS</sub>
Terminal capacity(Input, Output)		C <sub>in</sub> , C <sub>out</sub>	—	10	pF	V <sub>CC</sub> =5.0V T <sub>a</sub> =25 <sup>0</sup> C, F <sub>clk</sub> =1.0MHz
Operating current		I <sub>CC</sub> Write I <sub>CC</sub> Read	—	3 1	mA	V <sub>CC</sub> =5.5V, SCL=400KHz
Stillness current (SDA=SCL=V <sub>CC</sub> ) (WP=V <sub>SS</sub> ,A0,A1,A2=V <sub>SS</sub> )		I <sub>CCS</sub>	—	30 100	uA	V <sub>CC</sub> =3.0V V <sub>CC</sub> =5.5V

## (3) AC characteristics (VCC=2.5~5.5V standard operation mode)

Item	Symbol	VCC=2.5V-5.5V (Standard operation mode)		VCC=4.5V-5.5V (High-speed operation mode)		Unit	Index
		Min.	Max.	Min.	Max.		
Clock frequency	Fclk	—	100	—	400	KHz	
Clock High Time	THIGH	4000	—	900	—	ns	
Clock Low Time	TLOW	4700	—	1300	—	ns	
SDA, SCL falling time	TR	—	1000	—	300	ns	
SDA, SCL rising time	TF	—	300	—	300	ns	
START hold time	THD: STA	4000	—	600	—	ns	
START setup time	TSU: STA	4700	—	600	—	ns	
Data input hold time	THD: Data	0	—	0	—	ns	
Data input setup time	TSU: Data	250	—	100	—	ns	
STOP setup time	TSU: STO	4700	—	600	—	ns	
Output decision time from a clock	TAA	—	3500	100	900	ns	
Bus free time	TBUF	4700	—	1300	—	ns	
Rising time of Min VIH, VIL	TOF	—	250	20	250	ns	CB ≤ 100pF
Spike oppression	TSP	—	50	—	50	ns	
A write-in cycle time	TWR	—	10	—	10	ms	Byte and page mode
The number of times of data rewriting	—	1M	—	1M	—	cycles	VCC=5.0V Ta=25°C,

## 6. INTERFACE TIMING

### 6.1 INPUT SIGNAL TIMING SPECIFICATIONS

The input signal timing specifications are shown as the following table and timing diagram.

Signal	Item	Symbol	Min.	Typ.	Max.	Unit	Note
DCLK	Frequency	1/Tc	50	65	68	MHz	-
DE	Vertical Total Time	Tv	771	806	850	TH	-
	Vertical Addressing Time	TvD	768	768	768	TH	-
	Horizontal Total Time	TH	1200	1344	1500	Tc	-
	Horizontal Addressing Time	THD	1024	1024	1024	Tc	-

**INPUT SIGNAL TIMING DIAGRAM**

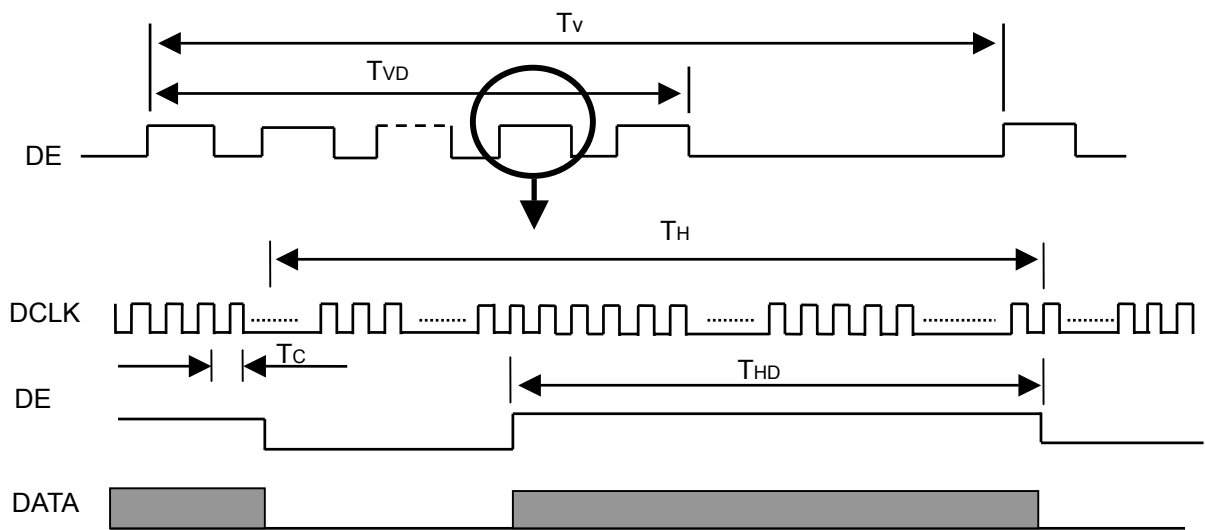

## 6.2 POWER ON/OFF SEQUENCE

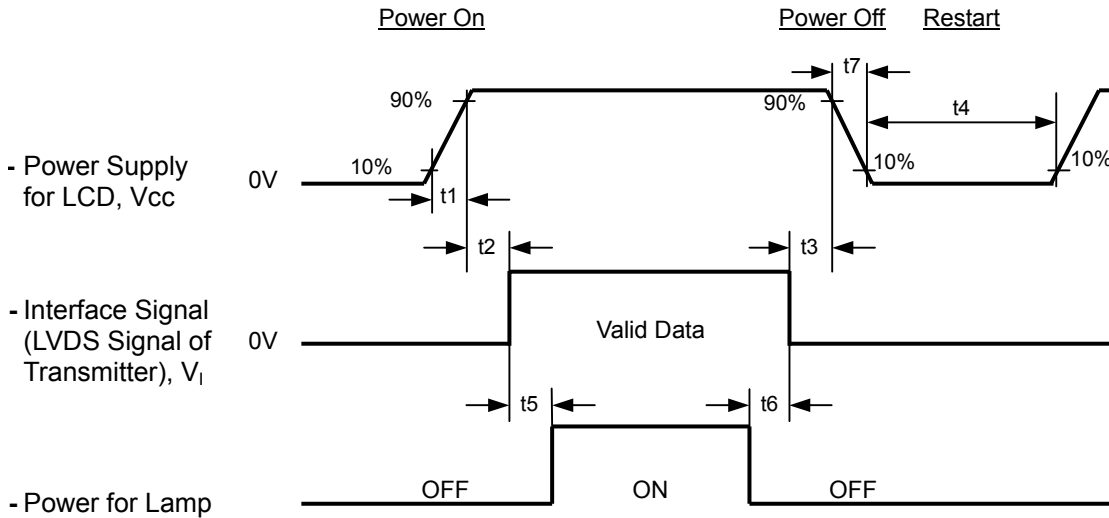

### Timing Specifications:

$$0.5 \leq t_1 \leq 10 \text{ msec}$$

$$0 < t_2 \leq 50 \text{ msec}$$

$$0 < t_3 \leq 50 \text{ msec}$$

$$t_4 \geq 500 \text{ msec}$$

$$t_5 \geq 200 \text{ msec}$$

$$t_6 \geq 200 \text{ msec}$$

Note (1) Please avoid floating state of interface signal at invalid period.

Note (2) When the interface signal is invalid, be sure to pull down the power supply of LCD V<sub>cc</sub> to 0 V.

Note (3) The Backlight inverter power must be turned on after the power supply for the logic and the interface signal is valid. The Backlight inverter power must be turned off before the power supply for the logic and the interface signal is invalid.

Note (4) Sometimes some slight noise shows when LCD is turned off (even backlight is already off). To avoid this phenomenon, we suggest that the V<sub>cc</sub> falling time had better to follow

$$t_7 \geq 5 \text{ msec}$$

## 7. OPTICAL CHARACTERISTICS

### 7.1 TEST CONDITIONS

Item	Symbol	Value	Unit
Ambient Temperature	Ta	25±2	°C
Ambient Humidity	Ha	50±10	%RH
Supply Voltage	V <sub>CC</sub>	3.3	V
Input Signal	According to typical value in "3. ELECTRICAL CHARACTERISTICS"		
Inverter Current	I <sub>L</sub>	5.0	mA
Inverter Driving Frequency	F <sub>L</sub>	61	KHz
Inverter	Sumida-H05-4915		

The measurement methods of optical characteristics are shown in Section 7.2. The following items should be measured under the test conditions described in Section 7.1 and stable environment shown in Note (6).

### 7.2 OPTICAL SPECIFICATIONS

Item		Symbol	Condition	Min.	Typ.	Max.	Unit	Note	
Contrast Ratio		CR	$\theta_x=0^\circ, \theta_y=0^\circ$ Viewing Normal Angle	350	500	-	-	(2), (5)	
Response Time		T <sub>R</sub>		-	5	10	ms	(3)	
		T <sub>F</sub>		-	11	16	ms		
Central Luminance of White		L <sub>AVE</sub>		145	175	-	cd/m <sup>2</sup>	(4), (5)	
White Variation of 5 Points		δW		-	-	1.25	-	(5), (6)	
Color Chromaticity	Red	R <sub>x</sub>		Viewing Normal Angle	TYP -0.03	0.595	TYP +0.03	-	(1)
		R <sub>y</sub>				0.338		-	
	Green	G <sub>x</sub>				0.320		-	
		G <sub>y</sub>				0.533		-	
	Blue	B <sub>x</sub>				0.150		-	
		B <sub>y</sub>	0.135			-			
	White	W <sub>x</sub>	0.313			-			
		W <sub>y</sub>	0.329			-			
Viewing Angle	Horizontal	θ <sub>x+</sub>	CR≥10	40	45	-	Deg.		
		θ <sub>x-</sub>		40	45	-			
	Vertical	θ <sub>y+</sub>		15	20	-			
		θ <sub>y-</sub>		40	45	-			

Note (1) Definition of Viewing Angle ( $\theta_x, \theta_y$ ):

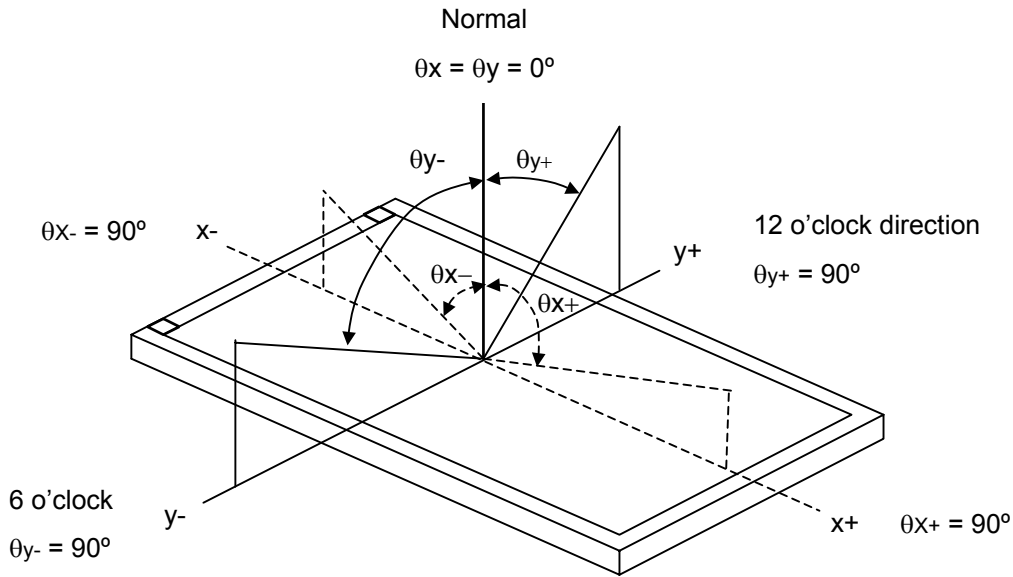

Note (2) Definition of Contrast Ratio (CR):

The contrast ratio can be calculated by the following expression.

$$\text{Contrast Ratio (CR)} = L_{63} / L_0$$

L63: Luminance of gray level 63

L 0: Luminance of gray level 0

$$\text{CR} = \text{CR} (5)$$

CR (X) is corresponding to the Contrast Ratio of the point X at Figure in Note (7).

Note (3) Definition of Response Time ( $T_R, T_F$ ):

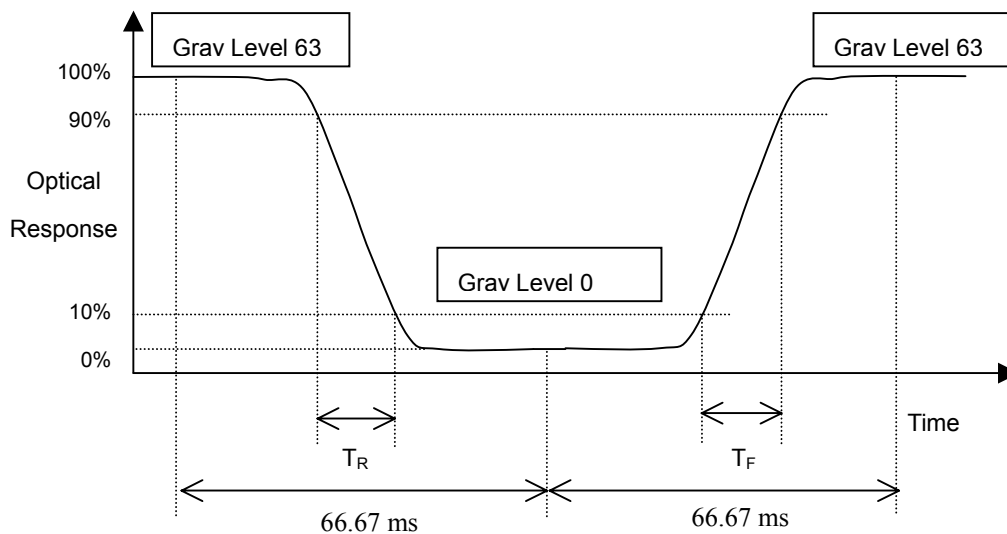



Note (4) Definition of Average Luminance of White ( $L_{AVE}$ ):

Measure the luminance of gray level 63 at 5 points

$$L_{AVE} = [L(1) + L(2) + L(3) + L(4) + L(5)] / 5$$

L(x) is corresponding to the luminance of the point X at Figure in Note (6)

Note (5) Measurement Setup:

The LCD module should be stabilized at given temperature for 20 minutes to avoid abrupt temperature change during measuring. In order to stabilize the luminance, the measurement should be executed after lighting Backlight for 20 minutes in a windless room.

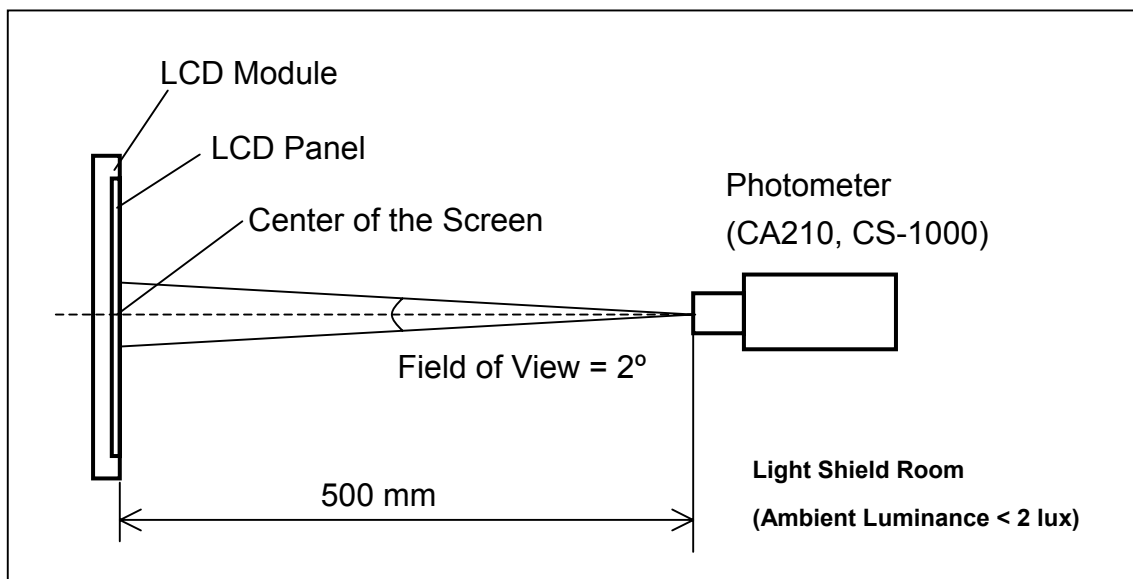

Note (6) Definition of White Variation ( $\delta W$ ):

Measure the luminance of gray level 63 at 5 points

$$\delta W = \text{Maximum } [L(1), L(2), L(3), L(4), L(5)] / \text{Minimum } [L(1), L(2), L(3), L(4), L(5)]$$

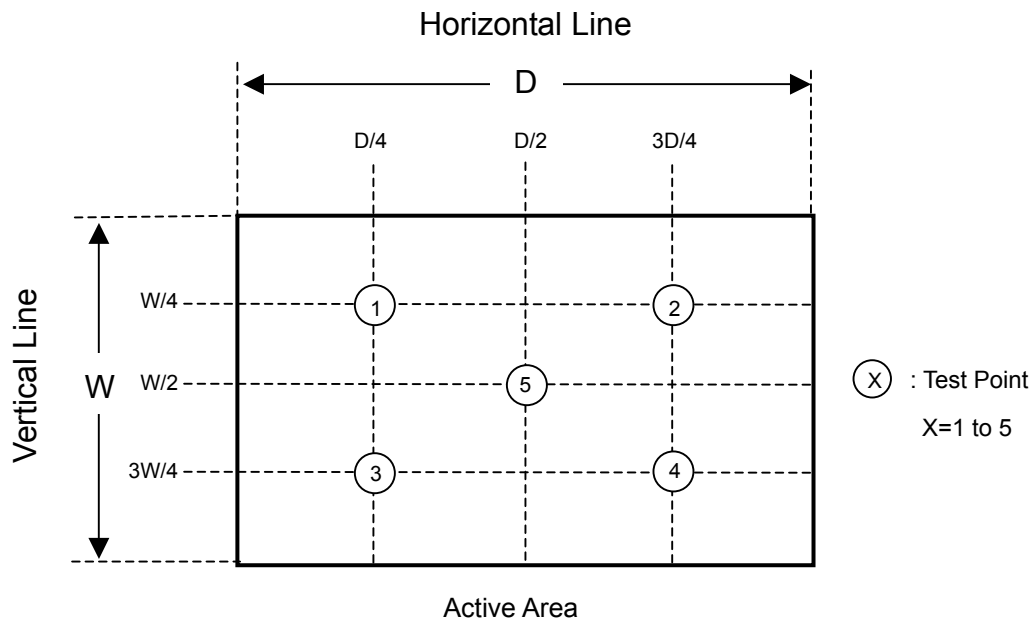

## 8. PRECAUTIONS

### 8.1 HANDLING PRECAUTIONS

- (1) The module should be assembled into the system firmly by using every mounting hole. Be careful not to twist or bend the module.
- (2) While assembling or installing modules, it can only be in the clean area. The dust and oil may cause electrical short or damage the polarizer.
- (3) Use fingerstalls or soft gloves in order to keep display clean during the incoming inspection and assembly process.
- (4) Do not press or scratch the surface harder than a HB pencil lead on the panel because the polarizer is very soft and easily scratched.
- (5) If the surface of the polarizer is dirty, please clean it by some absorbent cotton or soft cloth. Do not use Ketone type materials (ex. Acetone), Ethyl alcohol, Toluene, Ethyl acid or Methyl chloride. It might permanently damage the polarizer due to chemical reaction.
- (6) Wipe off water droplets or oil immediately. Staining and discoloration may occur if they left on panel for a long time.
- (7) If the liquid crystal material leaks from the panel, it should be kept away from the eyes or mouth. In case of contacting with hands, legs or clothes, it must be washed away thoroughly with soap.
- (8) Protect the module from static electricity, it may cause damage to the C-MOS Gate Array IC.
- (9) Do not disassemble the module.
- (10) Do not pull or fold the lamp wire.
- (11) Pins of I/F connector should not be touched directly with bare hands.

### 8.2 STORAGE PRECAUTIONS

- (1) High temperature or humidity may reduce the performance of module. Please store LCD module within the specified storage conditions.
- (2) It is dangerous that moisture come into or contacted the LCD module, because the moisture may damage LCD module when it is operating.
- (3) It may reduce the display quality if the ambient temperature is lower than 10 °C. For example, the response time will become slowly, and the starting voltage of lamp will be higher than the room temperature.

### 8.3 OPERATION PRECAUTIONS

- (1) Do not pull the I/F connector in or out while the module is operating.
- (2) Always follow the correct power on/off sequence when LCD module is connecting and operating. This can prevent the CMOS LSI chips from damage during latch-up.
- (3) The startup voltage of Backlight is approximately 1000 Volts. It may cause electrical shock while assembling with inverter. Do not disassemble the module or insert anything into the Backlight unit.

9. PACKING  
9.1 CARTON

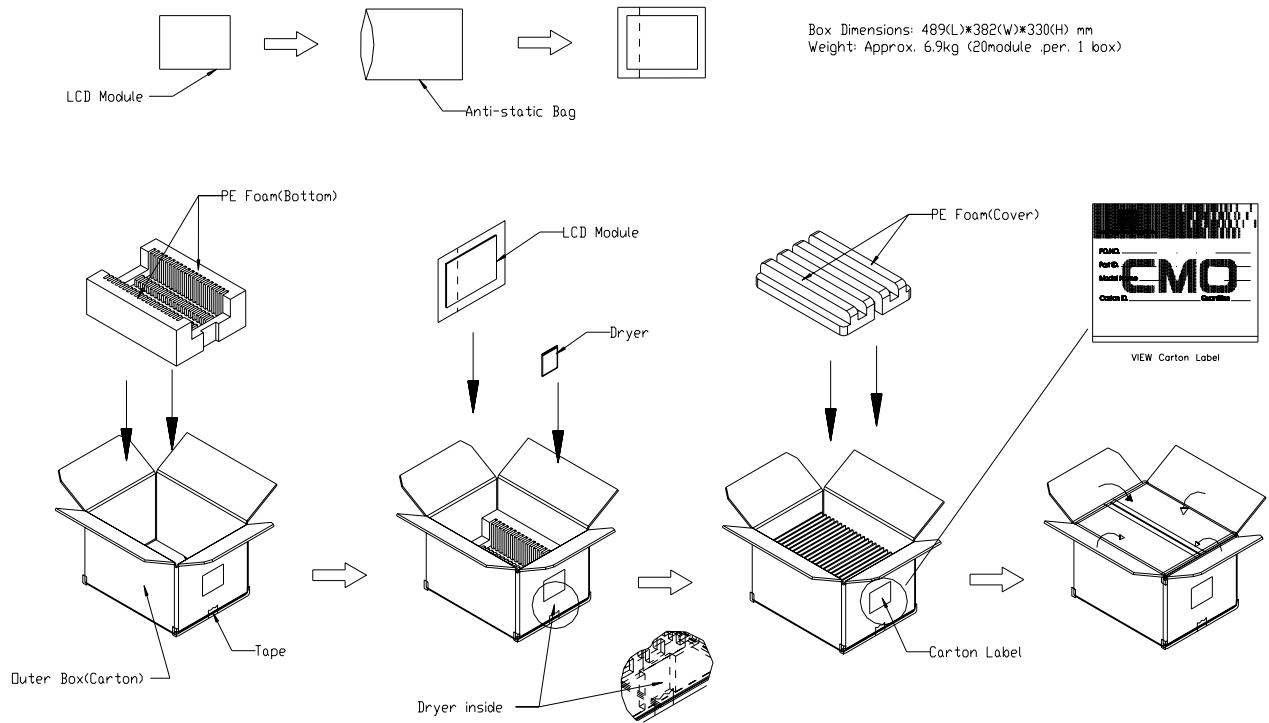

9.2 PALLET

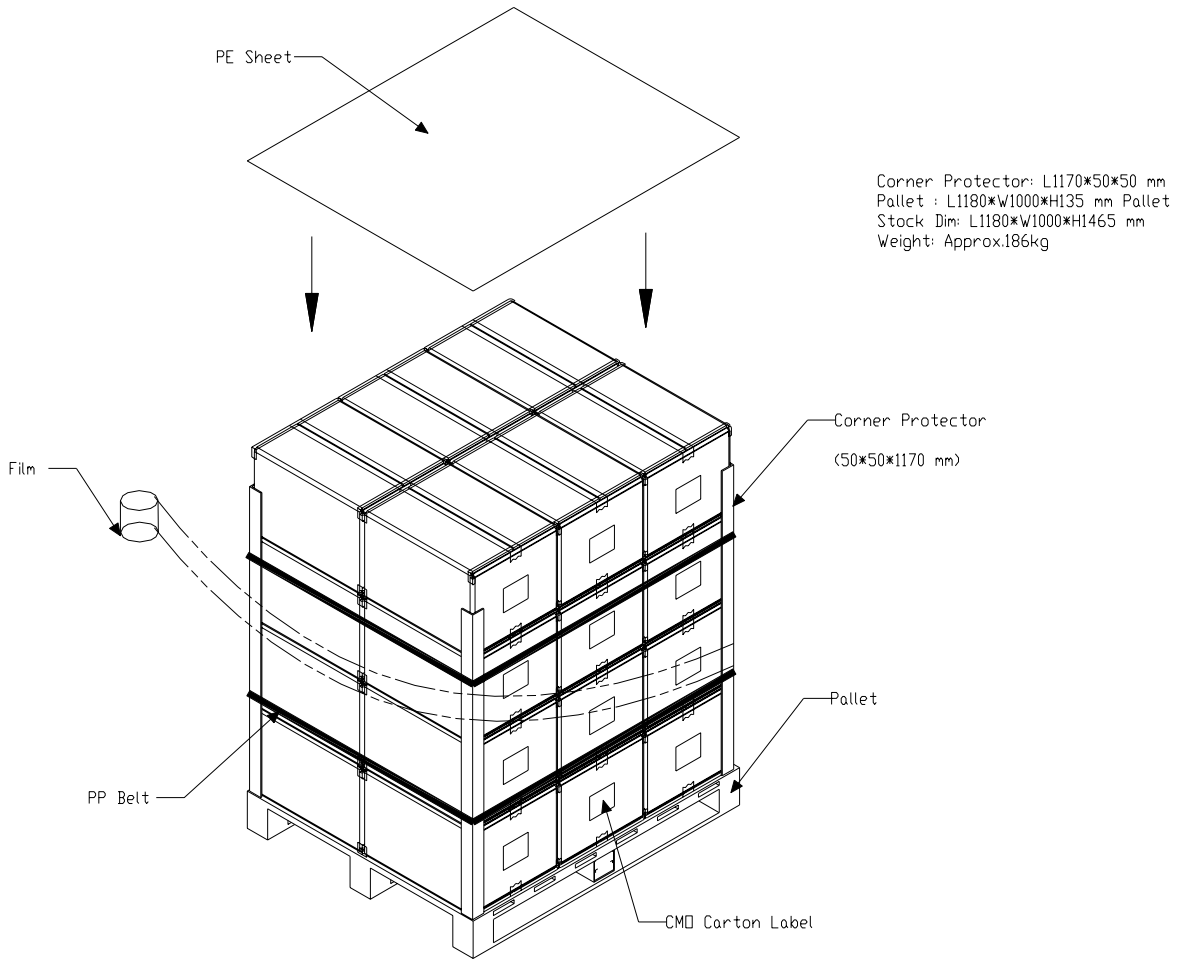

## 10. DEFINITION OF LABELS

### 10.1 CMO MODULE LABEL

The barcode nameplate is pasted on each module as illustration, and its definitions are as following explanation.

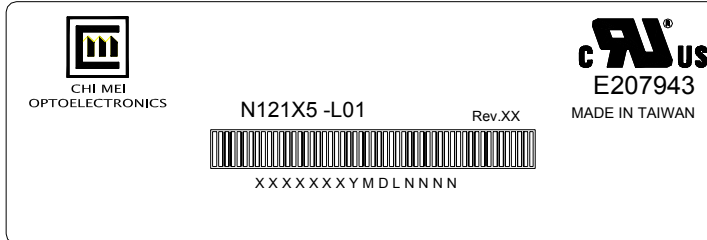

- (a) Model Name: N121X5 - L01
- (b) Revision: Rev. XX, for example: A1, ..., C1, C2 ...etc.
- (c) Serial ID: XXXXXXYMDXNNNN

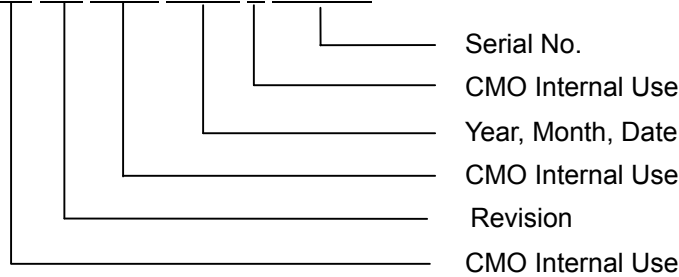

Serial ID includes the information as below:

- (a) Manufactured Date: Year: 1~9, for 2001~2009  
 Month: 1~9, A~C, for Jan. ~ Dec.  
 Day: 1~9, A~Y, for 1<sup>st</sup> to 31<sup>st</sup>, exclude I , O and U
- (b) Revision Code: cover all the change
- (c) Serial No.: Manufacturing sequence of product

### 10.2 CARTON LABEL

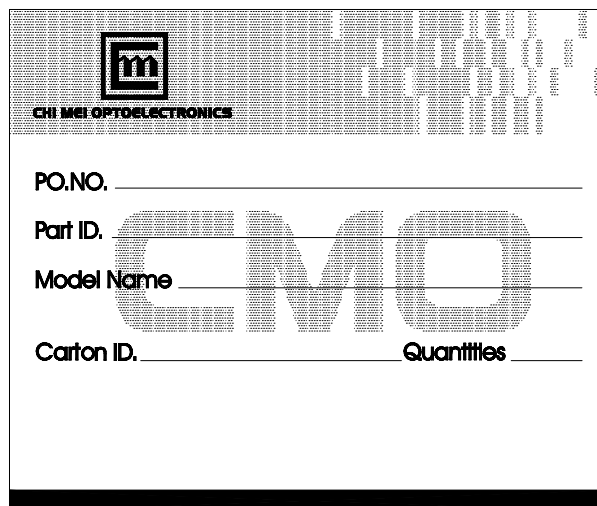

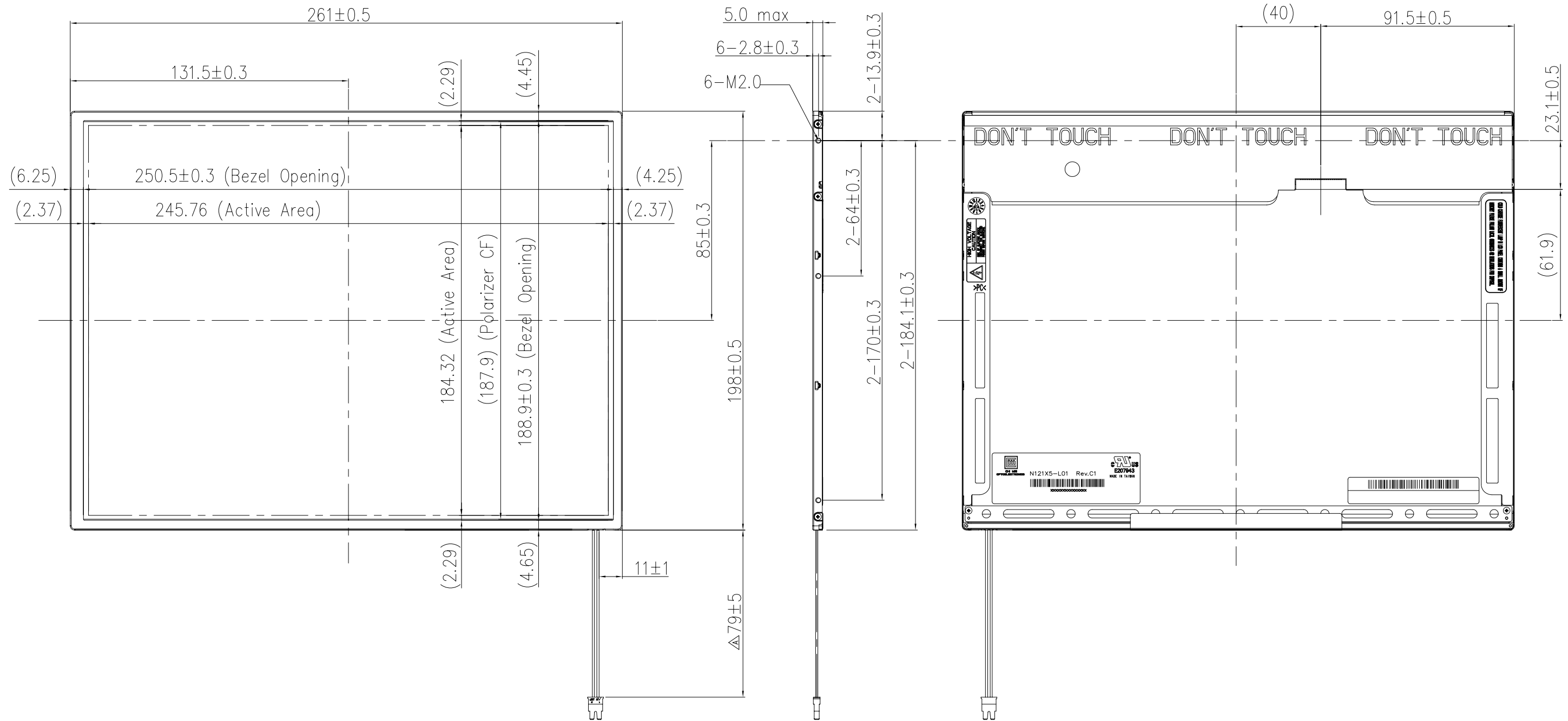

NOTES:

- 1."\*" MARKS THE DESIGN CRITICAL DIMENSION.
- 2."Ⓟ" MARKS THE PROCESS CRITICAL DIMENSION.
- 3.MAX.SCREW LENGTH: 2.5 mm.
- 4.MAX.SCREW TORQUE: 2.0 kgf-cm.
- 5.SIGNAL INTERFACE CONNECTOR: DF19L-20P-1H (HIROSE)
- 6.CCFL CONNECTOR: BHSR-02VS-1 (JST)

Mark	Description	Date	Changed_By	Approved_By	ECN No.	Remark
△	Modify the wire length from 60mm to 79mm.	15-Jul-2005	Mulciber Hsieh	Davis Wang		

TITLE		ASSY_MODULE_N121X5-L01 (NC1X501902)		2D REV. A	
Approved		Davis Wang		3D REV. 1.1	
Checked		Yule Sheu		Drawing No. N12154109A	
Designer		Mulciber Hsieh		Part No.	
Date		15-Jul-2005		Sheet 1 / 1 A1	
Scale		1:1		Unit:mm	
 CHI MEI OPTOELECTRONICS CORP. ALL RIGHTS RESERVED, COPYING FORBIDDEN.					