

**TFT COLOR LCD MODULE
NL6448AC20-06**

17 cm (6.5 type), 640×480 pixels
262144/4096 colors, incorporated edge-light type backlight
high brightness, inverter separated from module

DESCRIPTION

NL6448AC20-06 is a TFT(thin film transistor) active matrix color liquid crystal display(LCD) comprising amorphous silicon TFT attached to each signal electrode, a driving circuit and a backlight. NL6448AC20-06 has a built-in backlight. Backlight includes long-life-lamps and its lamps are replaceable.

The 17cm diagonal display area contains 640 × 480 pixels and can display 4096 or 262144 colors simultaneously.

NL6448AC20-06 is suitable for industrial application use, because the luminance is high, and the viewing direction is selectable by display scan select.

FEATURES

- High luminance (200 cd/m² Typ.: saturated value)
- Low reflection
- Wide viewing angle with retardation film
- Display reverse scan function
- 6-bit/4-bit digital RGB signals
- Edge type backlight with long-life-lamps (Two lamp holders, inverter)
- Variable luminance control
- Backlight lamp holder (65LHS-3L) replaceable
- Compatible to the mounting hole position of NL6448AC20-02 except for inverter.

APPLICATIONS

- Measuring instruments
- Display terminals for control system
- New media
- Control boards for NC machine
- Monitor for process controller



STRUCTURE AND FUNCTIONS

A TFT color LCD module comprises a TFT LCD panel, LSIs for driving liquid crystal, and a backlight. The TFT LCD panel is composed of a TFT array glass substrate superimposed on a color filter glass substrate with liquid crystal filled in the narrow gap between two substrates. The backlight apparatus is located on the backside of the LCD panel.

RGB (Red, Green, Blue) data signals are sent to LCD panel drivers after modulation into suitable forms for active matrix addressing through signal processor.

Each of the liquid crystal cells acts as an electro-optical switch that controls the light transmission from the backlight by a signal applied to a signal electrode through the TFT switch.

BLOCK DIAGRAM

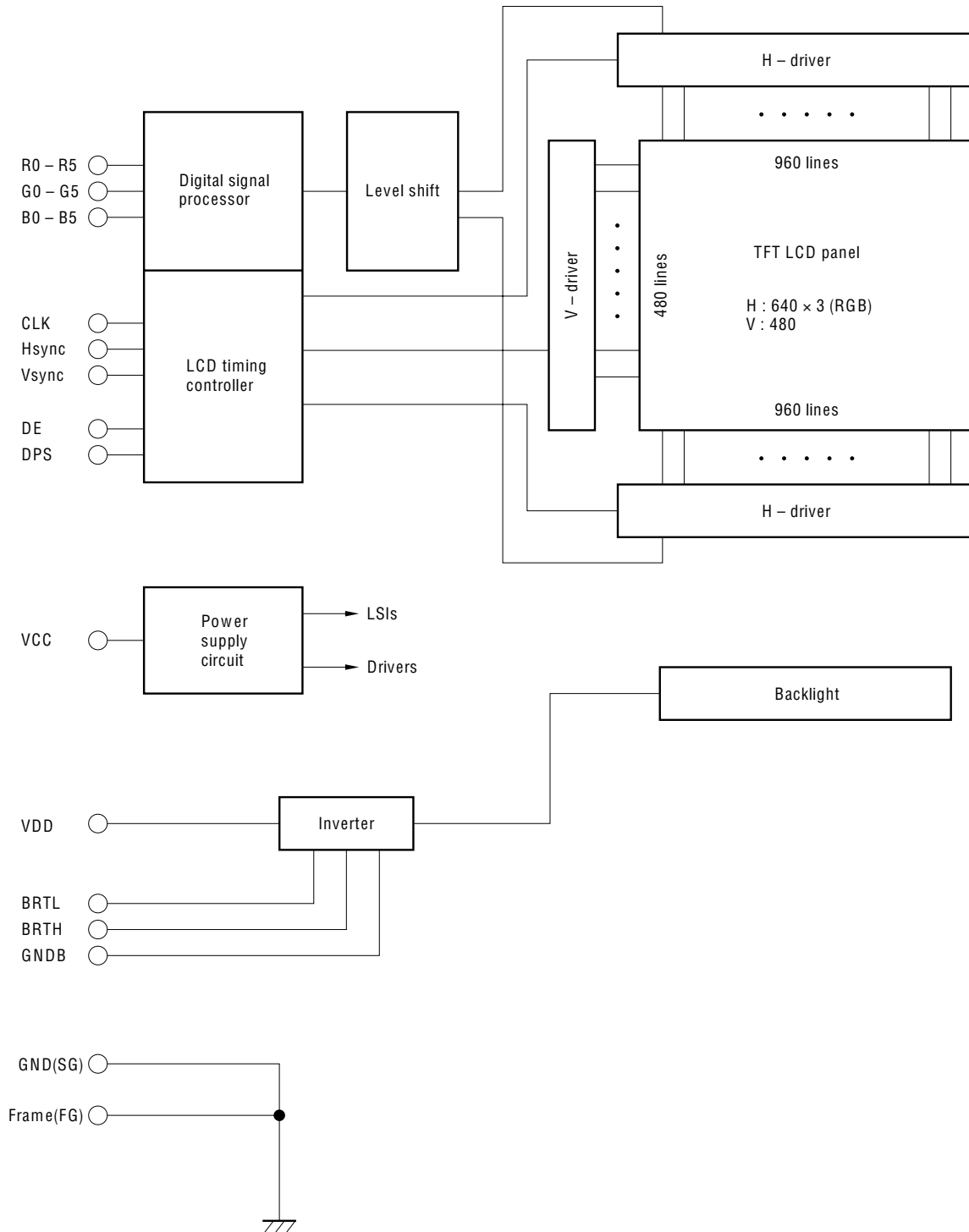

OUTLINE OF CHARACTERISTICS (at room temperature)

Display area	132.48 (H) × 99.36 (V) mm
Drive system	a-Si TFT active matrix
Display colors	262144 or 4096 colors
Number of pixels	640 × 480
Pixel arrangement	RGB vertical stripe
Pixel pitch	0.207 (H) × 0.207 (V) mm
Module size	178.8(H) × 126.8(V) × 11.0 Typ. (D) mm
Inverter size	26 (H) × 105 (V) × 9.5 Typ. (D) mm
Weight	237g (Typ.) + 17g (Typ., inverter)
Contrast ratio	150 : 1 (Typ.)
Viewing angle (more than the contrast ratio of 10:1)	
	• Horizontal : 50° (Typ. left side, right side)
	• Vertical : 35° (Typ. up side), 45° (Typ. down side)
Designed viewing direction	
	• wider viewing angle with contrast ratio : up side (12 o'clock, reverse scan) : down side (6 o'clock, normal scan)
	• wider viewing angle without image reversal : up side (12 o'clock, normal scan) : down side (6 o'clock, reverse scan)
	• optimum grayscale ($\gamma = 2.2$) : perpendicular
Color gamut	45% (Typ. At center, To NTSC)
Response time	40ms (Max.), "white" to "black"
Luminance	200cd/m ² (Typ.)
Signal system	6-/4-bit digital signals for each of RGB primary colors, Synchronous signals (Hsync, Vsync), Dot clock (CLK)
Supply voltage	5.0V (Logic, LCD driving), 5.0V (Backlight)
Backlight	Edge light type: two fluorescent lamps (cold cathode type)
Power consumption	6.0W (Typ.)

GENERAL SPECIFICATIONS

Item	Specifications	Unit
Module size	178.8 ± 0.5 (H) × 126.8 ± 0.5 (V) × 11.5 max. (D)	mm
Inverter size	26 ± 0.5 (H) × 105.0 ± 0.5 (V) × 10.0 max. (D)	mm
Display area	132.48 (H) × 99.36 (V)	mm
Number of pixels	640 (H) × 480 (V)	pixel
Dot pitch	0.069 (H) × 0.207 (V)	mm
Pixel pitch	0.207 (H) × 0.207 (V)	mm
Pixel arrangement	RGB (Red, Green, Blue) vertical stripe	—
Display colors	262144 / 4096	color
Weight	Module : 245 (max.) + inverter : 25 (max.)	g

ABSOLUTE MAXIMUM RATINGS

Parameter	Symbol	Ratings	Unit	Remarks
Supply voltage	V _{CC}	-0.3 to 6.5	V	T _a = 25°C
Input voltage	V _I	-0.3 to 6.5	V	V _I - V _{CC} < 3.0
Storage temp.	T _{ST}	-20 to 60	°C	—
Operating temp.	T _{OP}	0 to 60	°C	module surface note 1
Humidity (no condensation)	RH	≤ 95% relative humidity		T _a ≤ 40°C
		≤ 85% relative humidity		40 < T _a ≤ 50°C
		Absolute humidity shall not exceed T _a = 50°C, 85 % relative humidity level.		T _a > 50°C

note 1 : measured at the display area

ELECTRICAL CHARACTERISTICS

(1) Logic, LCD driving

T_a = 25°C

Parameter	Symbol	Min.	Typ.	Max.	Unit	Remarks
Supply voltage	V _{CC}	4.75	5.0	5.25	V	—
Logic input "L" voltage	V _{IL}	0	—	0.8	V	—
Logic input "H" voltage	V _{IH}	2.2	—	5.25	V	
Supply current	I _{CC}	—	*1) 300	450	mA	V _{CC} = 5.0 V

*1) : Checker flag pattern (in EIAJ ED-2522)

(2) Backlight

T_a = 25°C

Parameter	Symbol	Min.	Typ.	Max.	Unit	Remarks
Supply voltage	V _{DD}	4.75	5.0	5.25	V	—
Supply current	I _{DD}	—	900	1000	mA	200 cd/m ² (typ.)

SUPPLY VOLTAGE SEQUENCE

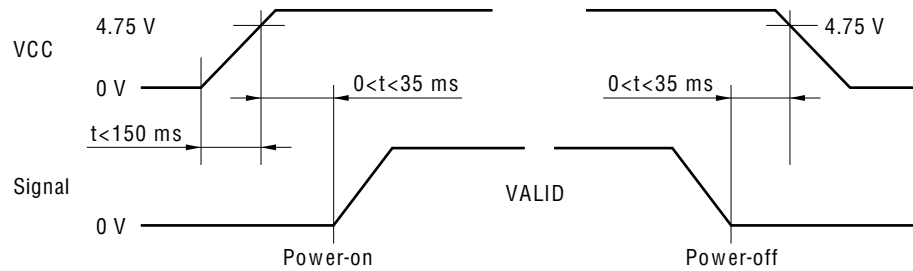

- *1 The supply voltage for input signals should be the same as VCC.
- *2 Apply VDD within the LCD operation period. When the backlight turns on before LCD operation or the LCD operation turns off before the backlight turns off, the display may momentarily become white.
- *3 When the power is off, please keep whole signals (Hsync, Vsync, CLK, DE, and DATA) low level or high impedance.

INTERFACE PIN CONNECTION

Module side connector
 CN31 ••• IL-310-T31PB-VF (No. 1 to 31)
 Supplier : Japan Aviation Electronics
 Industry Limited (JAE)

Mating connector
 IL-310-T31S-VF
 or
 DF9-31S-1V or DF9M-31S-1R
 Supplier : HIROSE ELECTRIC CO., LTD

(1) 6-bit interface signals, power supply

Pin No.	Symbol	Function
1	GND	Ground
2	CLK	Dot clock
3	Hsync	Horizontal synchronous
4	Vsync	Vertical synchronous
5	GND	Ground
6	R0	Red data (LSB)
7	R1	Red data
8	R2	Red data
9	R3	Red data
10	R4	Red data
11	R5	Red data (MSB)
12	GND	Ground
13	G0	Green data (LSB)
14	G1	Green data
15	G2	Green data
16	G3	Green data

Pin No.	Symbol	Function
17	G4	Green data
18	G5	Green data (MSB)
19	GND	Ground
20	B0	Blue data (LSB)
21	B1	Blue data
22	B2	Blue data
23	B3	Blue data
24	B4	Blue data
25	B5	Blue data (MSB)
26	GND	Ground
27	DE	Data enable
28	V _{CC}	Power supply
29	V _{CC}	Power supply
30	N.C.	Non-connection (Open)
31	DPS	Display scan select

LSB : Least Significant Bit
 MSB : Most Significant Bit

- note 1 :** VCC : All VCC terminals should be connected to 5.0 V.
- note 2 :** DPS : Normal scan is “L” or “Open”. And reverse scan is “H”.
- note 3 :** During the operation, do not change the operation mode : e. g. scan direction and 4/6-bit signal.
- note 4 :** Do not operate LCD module without input DE signal.

(2) 4-bit interface signals, power supply

Pin No.	Symbol	Function
1	GND	Ground
2	CLK	Dot clock
3	Hsync	Horizontal synchronous
4	Vsync	Vertical synchronous
5	GND	Ground
6	N.C.	Non-connection (Open)
7	N.C.	Non-connection (Open)
8	R0	Red data (LSB)
9	R1	Red data
10	R2	Red data
11	R3	Red data (MSB)
12	GND	Ground
13	V _{CC}	Power supply
14	N.C.	Non-connection (Open)
15	G0	Green data (LSB)
16	G1	Green data

Pin No.	Symbol	Function
17	G2	Green data
18	G3	Green data (MSB)
19	GND	Ground
20	N.C.	Non-connection (Open)
21	N.C.	Non-connection (Open)
22	B0	Blue data (LSB)
23	B1	Blue data
24	B2	Blue data
25	B3	Blue data (MSB)
26	GND	Ground
27	DE	Data enable
28	V _{CC}	Power supply
29	V _{CC}	Power supply
30	N.C.	Non-connection
31	DPS	Display scan select

LSB : Least Significant Bit

MSB : Most Significant Bit

note 1 : V_{CC} : All V_{CC} terminals should be connected to 5.0 V.

note 2 : DPS : Normal scan is "L" or "Open". And reverse scan is "H".

note 3 : During the operation, do not change the operation mode : e. g. scan direction and 4/6-bit signal.

note 4 : Do not use operate LCD module without input DE signal.

(3) Backlight

- Inverter side connector 1

CN1 ••• IL-Z-6PL-SMTY

Supplier : Japan Aviation Electronics Industry Limited (JAE)

Mating connector 1

IL-Z-6S-S125C3

Pin No.	Symbol	Function
1	GNDB	Backlight ground
2	GNDB	Backlight ground
3	V _{DD}	Power supply

Pin No.	Symbol	Function
4	V _{DD}	Power supply
5	BRTH	Luminance control input
6	BRTH	Luminance control input

- Inverter side connector 2

CN2 and CN3 ••• SM02 (8.0) B-BHS-TB

Supplier : J. S. T TRADING COMPANY, LTD.

Mating connector 2 (Lamp side)

BHR-03VS-1

Pin No.	Symbol	Function
1	VH	High voltage terminal
2	N.C.	Non-connection
3	GNDB	Backlight ground

note : ① A way of luminance control by a variable resistor

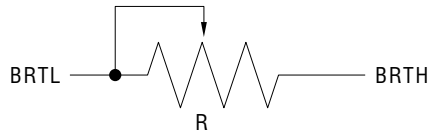

Mating variable resistor : 10 kΩ±5%
 Minimum luminance (Approx.15%) : R = 0 Ω
 Maximum luminance (100%) : R = 10 kΩ

② A way of luminance control by a voltage

The range of input voltage between BRTH and GNDB is as follows.

Minimum luminance (Approx. 15%) : 1.52 V

Maximum luminance (100%) : 1.9 V

③ Connector location

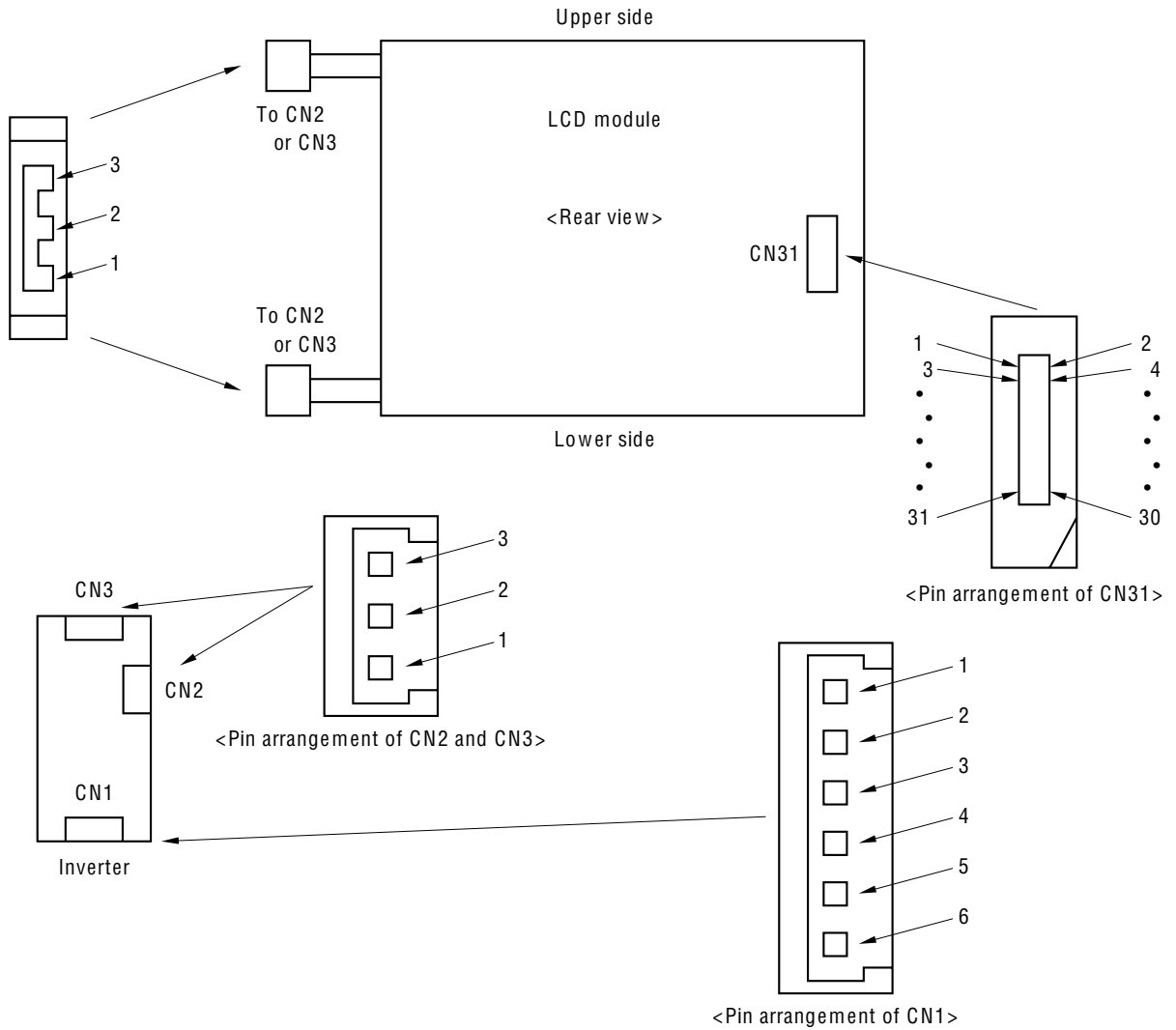

DISPLAY COLORS vs. INPUT DATA SIGNALS

(1) 6-bit interface signals

Display colors		Data signals (0 : Low level, 1 : High level)																	
		R5	R4	R3	R2	R1	R0	G5	G4	G3	G2	G1	G0	B5	B4	B3	B2	B1	B0
Basic colors	Black	0	0	0	0	0	0	0	0	0	0	0	0	0	0	0	0	0	0
	Blue	0	0	0	0	0	0	0	0	0	0	0	0	1	1	1	1	1	1
	Red	1	1	1	1	1	1	0	0	0	0	0	0	0	0	0	0	0	0
	Magenta	1	1	1	1	1	1	0	0	0	0	0	0	1	1	1	1	1	1
	Green	0	0	0	0	0	0	1	1	1	1	1	1	0	0	0	0	0	0
	Cyan	0	0	0	0	0	0	1	1	1	1	1	1	1	1	1	1	1	1
	Yellow	1	1	1	1	1	1	1	1	1	1	1	1	0	0	0	0	0	0
	White	1	1	1	1	1	1	1	1	1	1	1	1	1	1	1	1	1	1
Red grayscale	Black	0	0	0	0	0	0	0	0	0	0	0	0	0	0	0	0	0	0
	Dark	0	0	0	0	0	1	0	0	0	0	0	0	0	0	0	0	0	0
	↕																		
	Bright	1	1	1	1	0	1	0	0	0	0	0	0	0	0	0	0	0	0
	Red	1	1	1	1	1	0	0	0	0	0	0	0	0	0	0	0	0	0
Green grayscale	Black	0	0	0	0	0	0	0	0	0	0	0	0	0	0	0	0	0	0
	Dark	0	0	0	0	0	0	0	0	0	0	1	0	0	0	0	0	0	0
	↕																		
	Bright	0	0	0	0	0	0	1	1	1	1	0	1	0	0	0	0	0	0
	green	0	0	0	0	0	0	1	1	1	1	1	0	0	0	0	0	0	0
Blue grayscale	Black	0	0	0	0	0	0	0	0	0	0	0	0	0	0	0	0	0	0
	Dark	0	0	0	0	0	0	0	0	0	0	0	0	0	0	0	0	0	1
	↕																		
	Bright	0	0	0	0	0	0	0	0	0	0	0	0	1	1	1	1	0	1
	Blue	0	0	0	0	0	0	0	0	0	0	0	0	1	1	1	1	1	0

Note : Colors are developed in combination with 6 bit signal (64 steps in grayscale) of each primary red, green, and blue color.
 This process can result in up to 262144 (64 × 64 × 64) colors.

(2) 4-bit interface signals

Display colors		Data signals (0 : Low level, 1 : High level)											
		R3	R2	R1	R0	G3	G2	G1	G0	B3	B2	B1	B0
Basic colors	Black	0	0	0	0	0	0	0	0	0	0	0	0
	Blue	0	0	0	0	0	0	0	0	1	1	1	1
	Red	1	1	1	1	0	0	0	0	0	0	0	0
	Magenta	1	1	1	1	0	0	0	0	1	1	1	1
	Green	0	0	0	0	1	1	1	1	0	0	0	0
	Cyan	0	0	0	0	1	1	1	1	1	1	1	1
	Yellow	1	1	1	1	1	1	1	1	0	0	0	0
	White	1	1	1	1	1	1	1	1	1	1	1	1
Red grayscale	Black	0	0	0	0	0	0	0	0	0	0	0	0
	Dark	0	0	1	0	0	0	0	0	0	0	0	0
	↕												
	Bright	1	1	0	1	0	0	0	0	0	0	0	0
	Red	1	1	1	1	0	0	0	0	0	0	0	0
Green grayscale	Black	0	0	0	0	0	0	0	0	0	0	0	0
	Dark	0	0	0	0	0	0	0	1	0	0	0	0
	↕												
	Bright	0	0	0	0	1	1	0	1	0	0	0	0
	green	0	0	0	0	1	1	1	0	0	0	0	0
Blue grayscale	Black	0	0	0	0	0	0	0	0	0	0	0	0
	Dark	0	0	0	0	0	0	0	0	0	0	1	0
	↕												
	Bright	0	0	0	0	0	0	0	0	1	1	0	1
	Blue	0	0	0	0	0	0	0	0	1	1	1	0
	Blue	0	0	0	0	0	0	0	0	1	1	1	1

Note : Colors are developed in combination with 4 bit signal (16 steps in grayscale) of each primary red, green, and blue color. This process can result in up to 4096 (16 × 16 × 16) colors.

INPUT SIGNAL TIMING

(1) Input signal specifications

Parameter		Symbol	Min.	Typ.	Max.	Unit	Remarks	
CLK	Frequency	1 /tc	21.0	25.175	29.0	MHz	39.722 ns (Typ.)	
	Duty	t ch / t c	0.4	0.5	0.6	—	—	
	Rise, fall	t crf	—	—	10	ns	—	
Hsync	Period	t h	30.0	31.778	33.6	μ s	31.468 kHz (Typ.)	
			—	800	—	CLK		
	Display period	t hd	640			CLK	—	
	Front-porch	t hf	2	16	—	CLK	—	
	Pulse width	t hp	10	96	—	CLK	—	
	Back-porch	t hb	5	48	—	CLK	—	
	*) t hp + t hb			64	144	—	CLK	—
	CLK-Hsync timing	t hch	12	—	—	ns	—	
	Hsync-CLK timing	t hcx	8	—	—	ns	—	
	Hsync-Vsync timing	t vh	15	—	—	ns	—	
	Vsync-Hsync timing	t vs	15	—	—	ns	—	
	Rise, fall	t hrf	—	—	10	ns	—	
Vsync	Period	t v	16.1	16.683	17.2	ms	59.94 Hz (Typ.)	
			—	525	—	H		
	Display period	t vd	480			H	—	
	Front-porch	t vf	1	12	—	H	—	
	Pulse width	t vp	2	2	—	H	—	
	Back-porch	t vb	4	31	—	H	—	
	*) t vp + t vb			6	33	—	H	—
Rise, fall		—	—	10	ns	—		
DATA R0-R5 G0-G5 B0-B5	CLK-DATA timing	t ds	8	—	—	ns	—	
	DATA-CLK timing	t dh	12	—	—	ns	—	
	Rise, fall	t drf	—	—	10	ns	—	
DE	DE-CLK timing	t es	8	—	—	ns	—	
	CLK-DE timing	t eh	12	—	—	ns		
	Rise, fall	t erf	—	—	10	ns		

note 1 : All parameters should be kept within the specified range.

note 2 : Do not operate LCD module without input DE signal.

(2) Definition of input signal timing

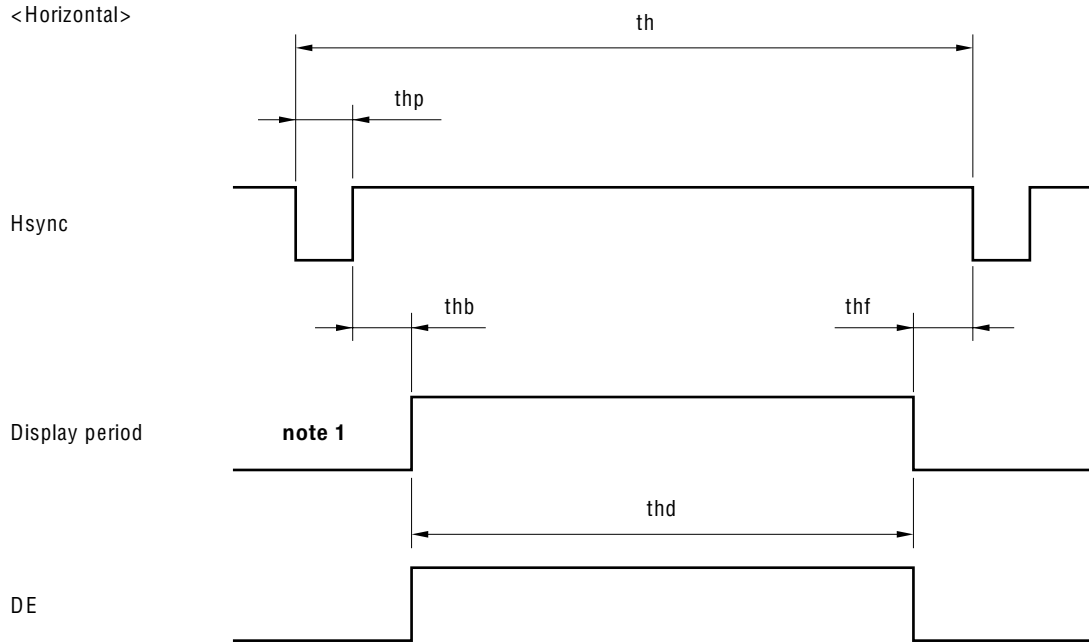
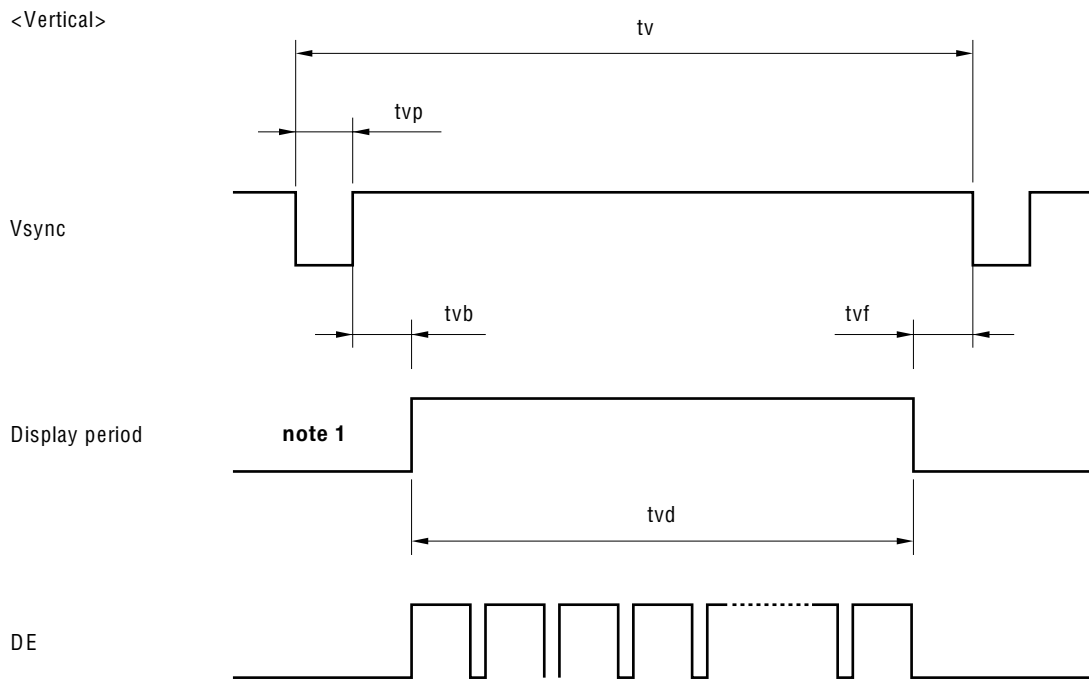

- note 1** : Display period does not exist as signals.
- note 2** : Set the total of $thp + thb$ and $tvp + tvb$ as the table of input signal timing, otherwise display position is shifted to right or left side, or to up or down side.
- note 3** : Do not operate LCD module without input DE signal.

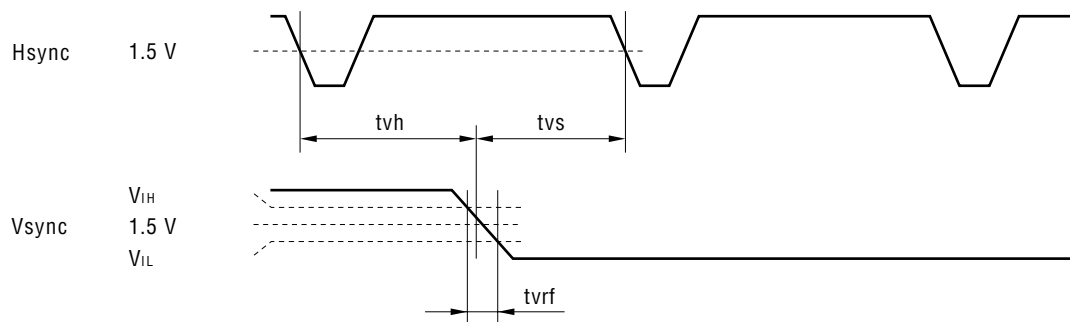
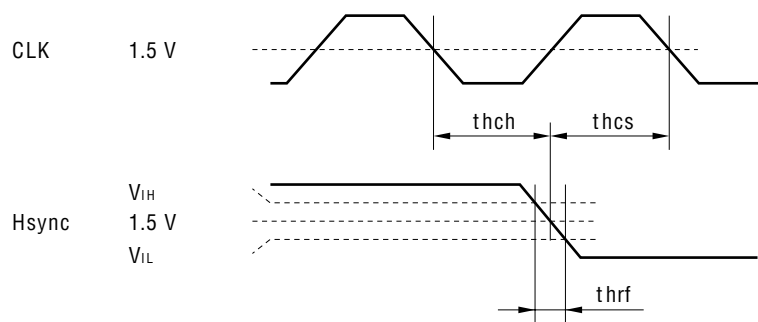
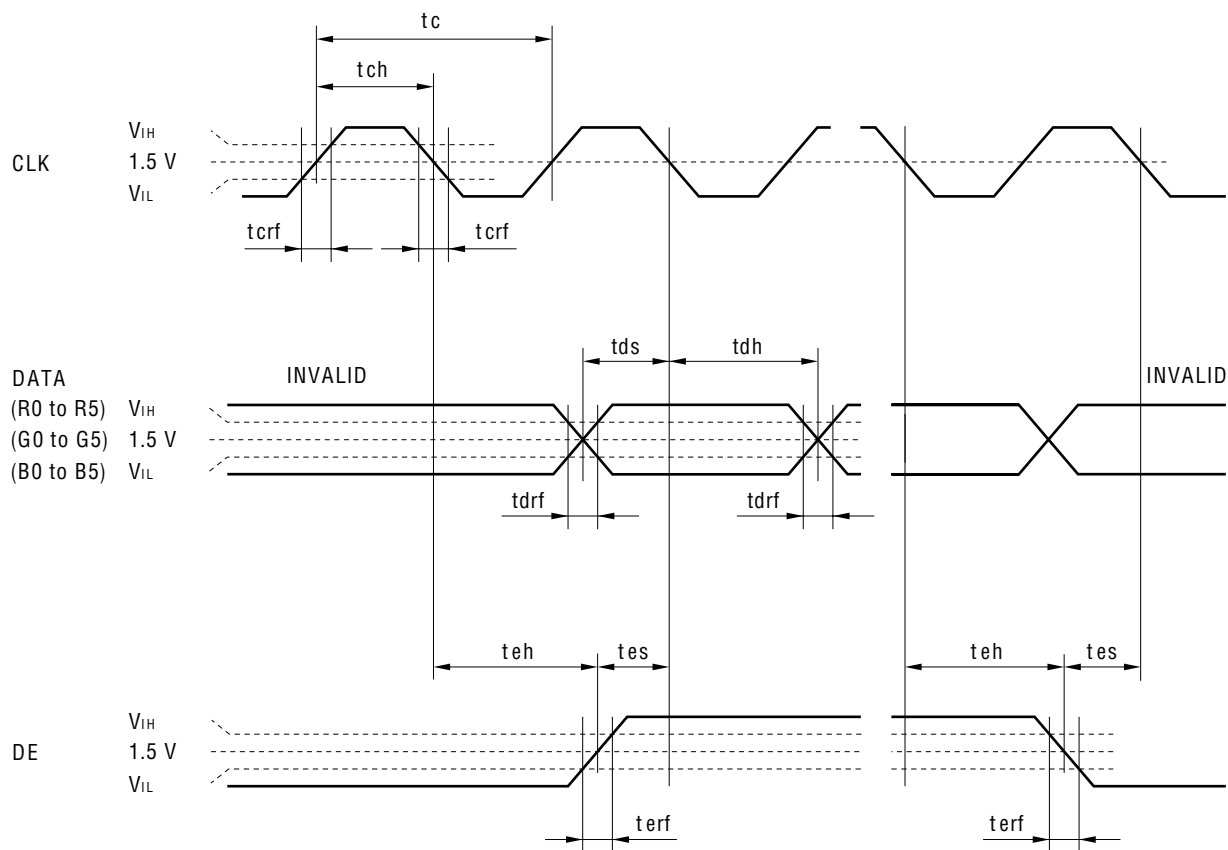

(3) Input signal timing chart

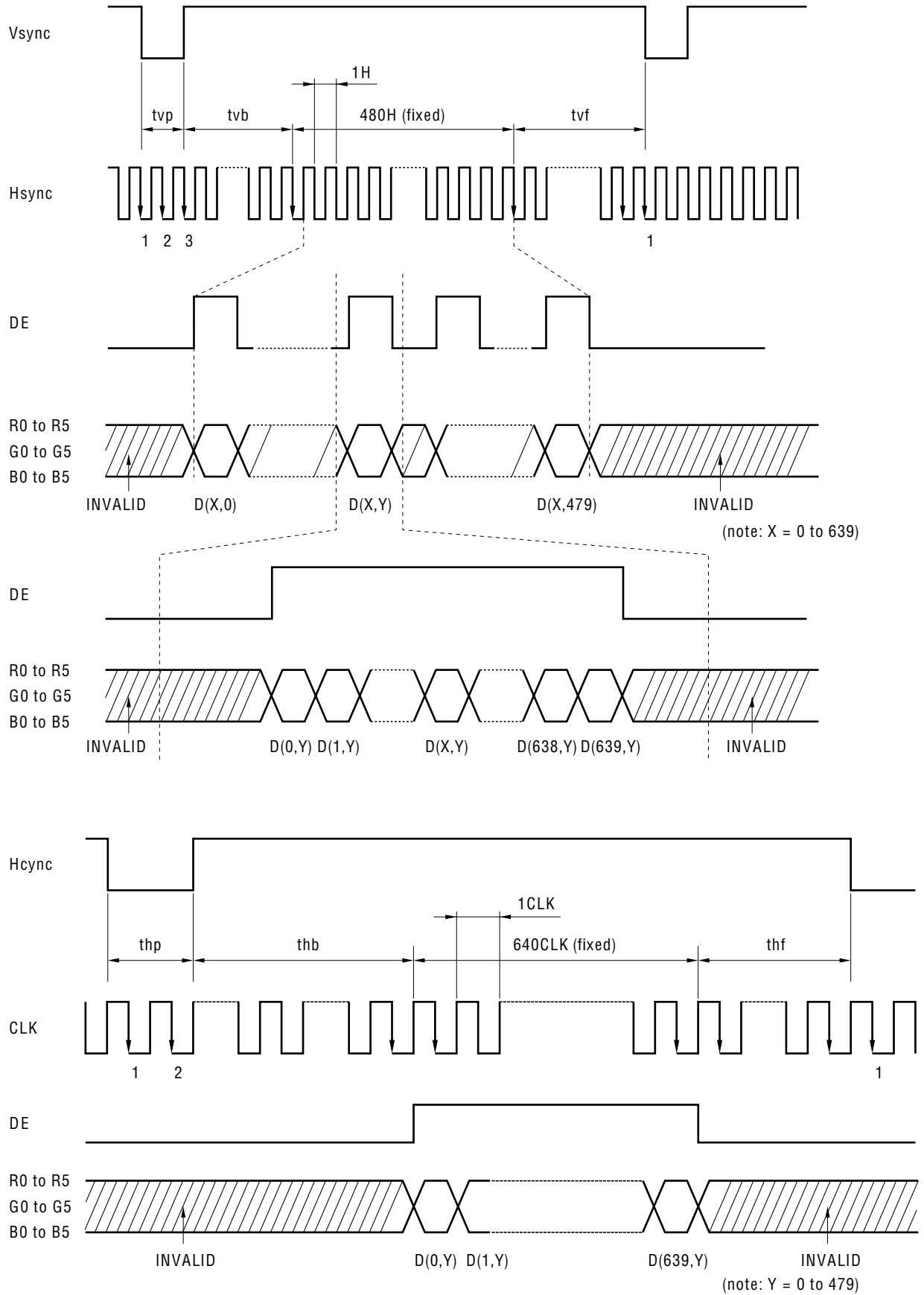

DISPLAY POSITION

Normal scan: DPS = "L" or "OPEN"

D (0, 0)	D (1, 0)	-----	D (X, 0)	-----	D (638, 0)	D (639, 0)
D (0, 1)	D (1, 1)	-----	D (X, 1)	-----	D (638, 1)	D (639, 1)
		-----		-----		
D (0, Y)	D (1, Y)	-----	D (X, Y)	-----	D (638, Y)	D (639, Y)
		-----		-----		
D (0, 478)	D (1, 478)	-----	D (X, 478)	-----	D (638, 478)	D (639, 478)
D (0, 479)	D (1, 479)	-----	D (X, 479)	-----	D (638, 479)	D (639, 479)

Reverse scan: DPS = "H"

D (639, 479)	D (638, 479)	-----	D (X, 479)	-----	D (1, 479)	D (0, 479)
D (639, 478)	D (638, 478)	-----	D (X, 478)	-----	D (1, 478)	D (0, 478)
		-----		-----		
D (639, Y)	D (638, Y)	-----	D (X, Y)	-----	D (1, Y)	D (0, Y)
		-----		-----		
D (639, 1)	D (638, 1)	-----	D (X, 1)	-----	D (1, 1)	D (0, 1)
D (639, 0)	D (638, 0)	-----	D (X, 0)	-----	D (1, 0)	D (0, 0)

note 1 : Below drawings show relations between the scan direction and the viewing direction.

Normal scan

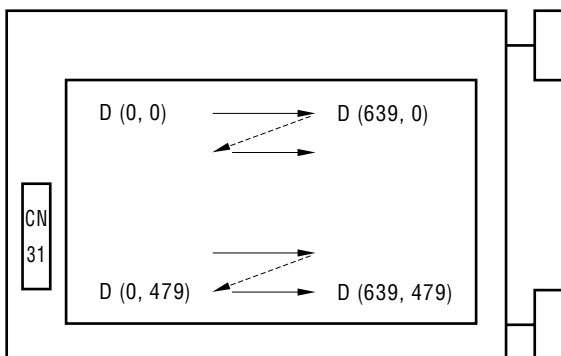

Reverse scan

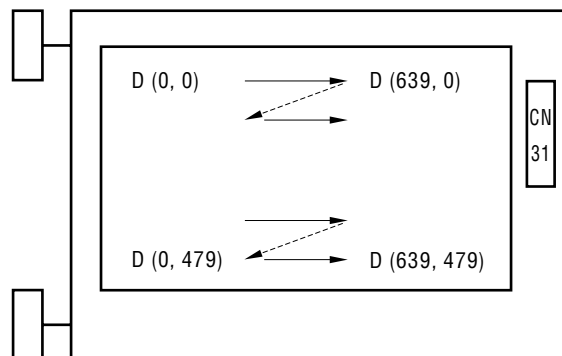

OPTICAL CHARACTERISTICS

Ta = 25°C note 1

Parameter		Symbol	Condition	Min.	Typ.	Max.	Unit	Remark
Viewing angle range	Horizontal	θ_{x+}	CR>10, $\theta_y = \pm 0^\circ$	45	50	—	deg.	note 2
		θ_{x-}	CR>10, $\theta_y = \pm 0^\circ$	45	50	—	deg.	
	Vertical	θ_{y+}	CR>10, $\theta_x = \pm 0^\circ$	30	35	—	deg.	
		θ_{y-}	CR>10, $\theta_x = \pm 0^\circ$	40	45	—	deg.	
Contrast ratio		CR	$\gamma = 2.2$ viewing	80	150	—	—	note 3 and note 4
			Best contrast	—	250	—	—	
Response time		t pd	White to black	—	—	40	ms	note 5
Color gamut		C	at center, to NTSC	40	45	—	%	—
Luminance		Lu	note 3	150	200	—	cd/m ²	note 6
Luminance uniformity		—	max./min	—	—	1.25	—	note 7

note 1 : V_{CC} = 5.0 V, V_{DDB} = 5.0 V

note 2 : Definitions of viewing angle are as follows.

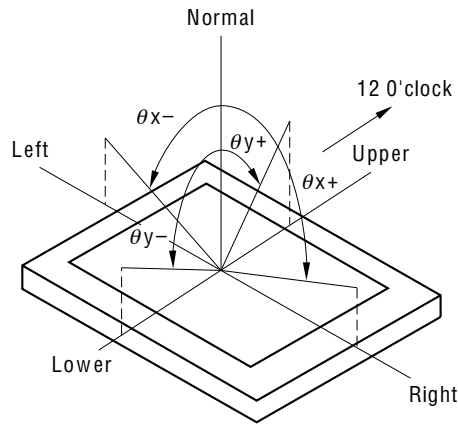

note 3 : $\gamma = 2.2$ viewing angle : $\theta_x = \pm 0^\circ$, $\theta_y = \pm 0^\circ$. At center.

Best contrast angle : $\theta_x = \pm 0^\circ$, $\theta_y = -10^\circ$. At center.

note 4 : The contrast ratio is calculated by using the following formula.

$$\text{Contrast ratio (CR)} = \frac{\text{Luminance with all pixels in "white"}}{\text{Luminance with all pixels in "black"}}$$

The Luminance is measured in darkroom.

note 5 : Definition of response time is as follows.

Photodetector output signal is measured when the Luminance changes "white" to "black". Response time is the time between 10% and 100% of the photodetector output amplitude.

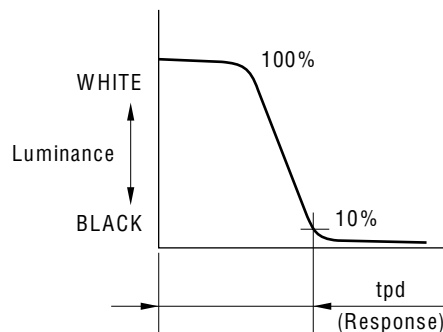

note 6 : The luminance is measured after 20 minutes from the module works, with all pixels in "white". Typical value is measured after luminance saturation.

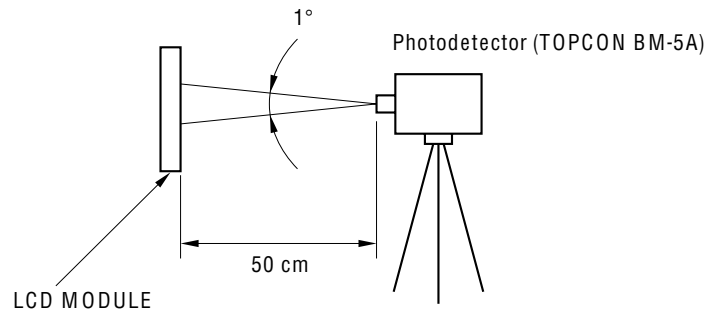

note 7 : The luminance uniformity is calculated by using following formula.

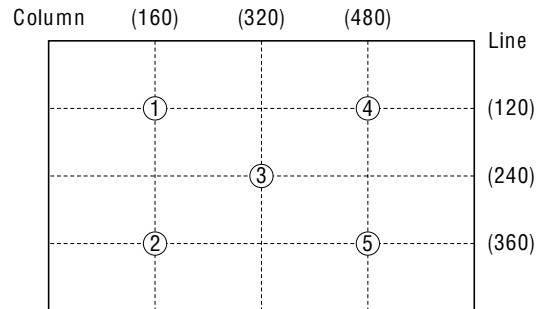

$$\text{Luminance uniformity} = \frac{\text{Maximum luminance}}{\text{Minimum luminance}}$$

The luminance is measured at near the five points shown below.



GENERAL CAUTION

Next figures and sentence are very important, please understand these contents as follows.

 CAUTION	<p>This figure is a mark that you will get hurt and/or the module will have damages when you make a mistake to operate.</p>
	<p>This figure is a mark that you will get an electric shock when you make a mistake to operate.</p>
	<p>This figure is a mark that you will get hurt when you make a mistake to operate</p>

 **CAUTION**

	<p>Do not touch an inverter --on which is stuck a caution label-- while the LCD module is under the operation, because of dangerous high voltage.</p>
---	---

(1) Caution when taking out the module

- ① Pick the pouch only, in taking out module from a carrier box.

(2) Caution for handling the module

- ① As the electrostatic discharges may break the LCD module, handle the LCD module with care against electrostatic discharges.
- ②  As the LCD panel and backlight element are made from fragile glass material, impulse and pressure to the LCD module should be avoided.
- ③ As the surface of polarizer is very soft and easily scratched, use a soft dry cloth without chemicals for cleaning.
- ④ Do not pull the interface connectors in or out while the LCD module is operating.
- ⑤ Put the module display side down on a flat horizontal plane.
- ⑥ Handle connectors and cables with care.
- ⑦ When the module is operating, do not lose CLK, Hsync, or Vsync signal. If any one of these signals is lost, the LCD panel would be damaged.
- ⑧ The torque to nrounding screw should never exceed 0.20 N•m (2 Kgf•cm).

(3) Caution for the atmosphere

- ① Dew drop atmosphere should be avoided.
- ② Do not store and/or operate the LCD module in a high temperature and/or high humidity atmosphere. Storage in an electro-conductive polymer packing pouch and under relatively low temperature atmosphere is recommended.
- ③ This module uses cold cathod fluorescent lamp. Therefore, The life time of lamp becomes short conspicuously at low temperature.
- ④ Do not operate the LCD module in a high magnetic field.

(4) Caution for the module characteristics

- ① Do not apply fixed pattern data signal to the LCD module at product agjing. Applying fixed pattern for a long time may cause image sticking.

(5) Other cautions

- ① Do not disassemble and/or reassemble LCD module.
- ② Do not readjust variable resistor or switch etc.
- ③ When returning the module for repair or etc, please pack the module not to be broken. We recommend to the original shipping packages.

Liquid Crystal Display has the following specific characteristics. There are not defects or malfunctions.

The display condition of LCD module may be affected by the ambient temperature.

The LCD module uses cold cathode tube for backlighting. Optical characteristics, like luminance or uniformity, will change during time.

Uneven brightness and/or small spots may be noticed depending on different display patterns.

OUTLINE DRAWING / FRONT SIDE (Unit in mm)

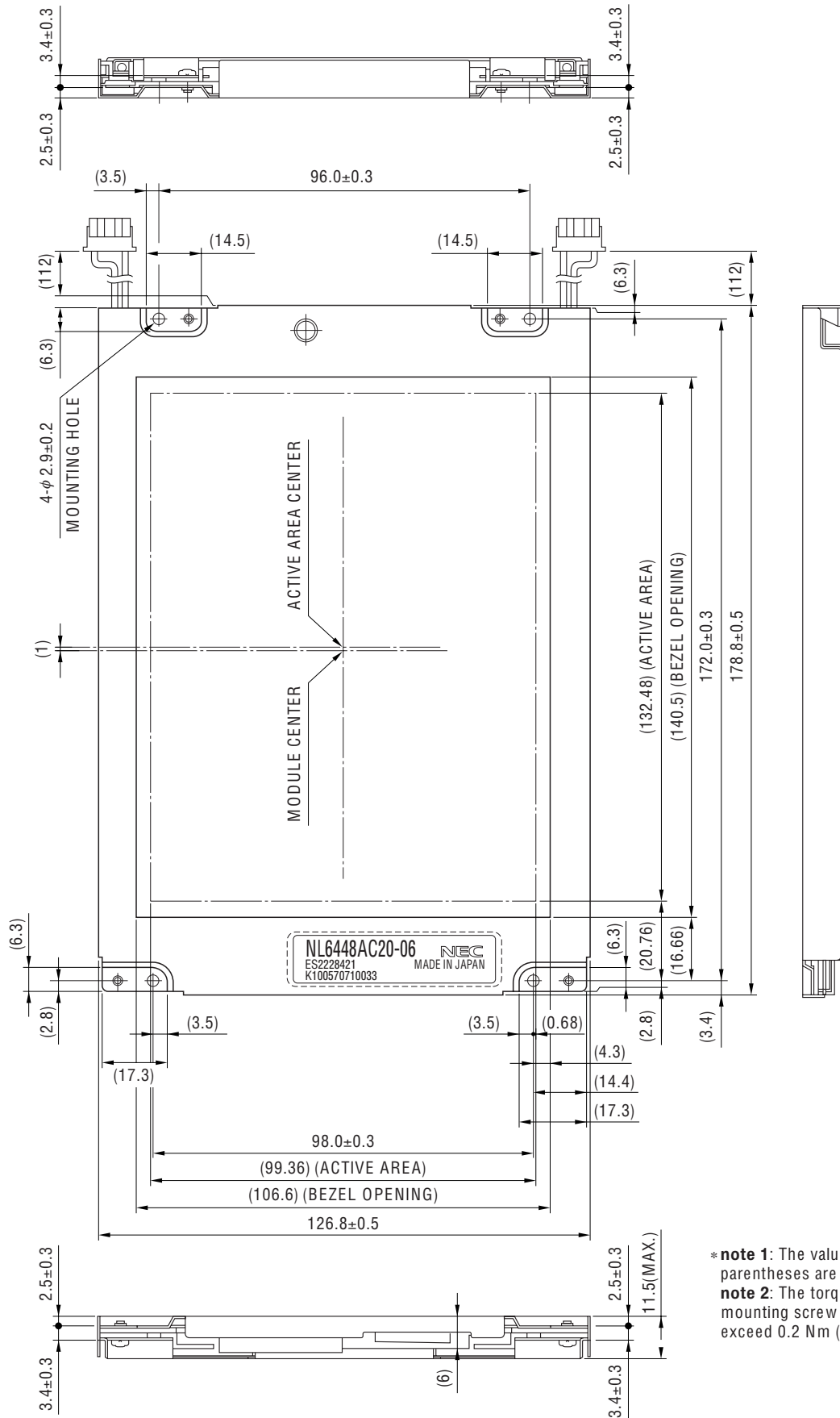

* note 1: The value in parentheses are for reference.
 note 2: The torque to mounting screw should never exceed 0.2 Nm (2 kgf cm)

OUTLINE DRAWING / REAR SIDE (Unit in mm)

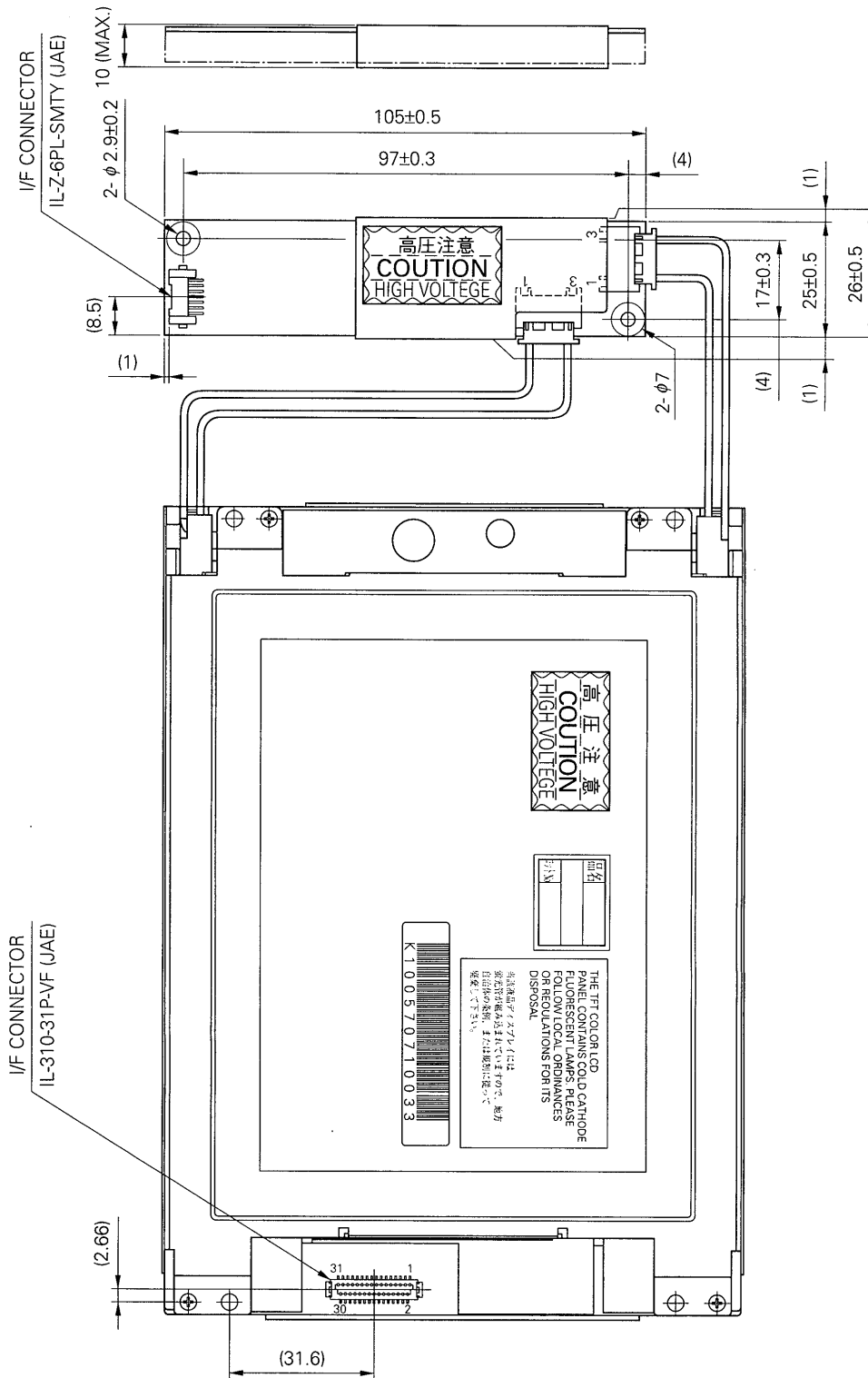

No part of this document may be copied or reproduced in any form or by any means without the prior written consent of NEC Corporation.

NEC Corporation does not assume any liability for infringement of patents, copyrights or other intellectual property rights of third parties by or arising from use of a device described herein or any other liability arising from use of such device. No license, either express, implied or otherwise, is granted under any patents, copyrights or other intellectual property rights of NEC Corporation or of others.